

PLASTIC MATERIAL HANDLING PRODUCTS

Application and Performance Guide



C O N T E N T S



INTRODUCTION

Preface	1
Acknowledgement	3
History	4-5
Materials Processes	6-7



PLASTIC MATERIAL HANDLING PRODUCTS

Material Handling Products Flow Chart.....	8
Product Configurations	9-11
Chart of Common Features & Options.....	12
Material Handling Equipment	13-17



PERFORMANCE RATINGS

Floor	18
Fork.....	19
Rack	20
Conveyor	21
Slip Resistance	22
Durability	23
Pack.....	24
Life Cycle.....	25
Derating Considerations	25
Site Testing.....	26-28
Application Analysis Form	29



ACKNOWLEDGEMENT

In 1994 TriEnda implemented its new, refined focus on plastic material handling products. It was my mission to design structural material handling products to meet specific customers' performance criteria.

I was impassioned and consumed with my responsibilities, yet immensely frustrated. During my 30 years of machine design experience, if I had questions relating to hydraulics, I simply opened a hydraulics systems design manual. Or, if I hit stumbling blocks regarding a machine's electrical circuits, I could thumb through the pages of an electrical circuitry manual to find answers. Plastic was different: There were few rules, guidelines or published manuals with proven test standards to reference for material handling products.

Before I began to compile years of research, performance tests, and TriEnda's standards to create this book, it took a simple grocery shopping experience with my wife and a splintered wood pallet on the grocer's floor to ignite the spark.

I hope this book will be the catalyst for change from wood to plastic material handling products. I believe TriEnda has forged new ground in influencing industry performance tests and standards; which should be useful for all.

I dedicate this book to all the people on the shop floor who help make plastic material handling products a reality. I especially thank my family and wife, Susan, for all their support and patience over the years.

Thank you,

A handwritten signature in black ink, appearing to read 'Kenyon Brown', written in a cursive style.

Plastic – The Progressive Pallet Material

For 100 years the familiar wood pallet has been the foundation for storing and transporting products. Wood was inexpensive, easily worked, and widely available.

As a result, modern materials handling systems—from fork trucks and conveyors to racks and semi-trailers—are designed to fit the dimensions and characteristics of this venerable technology.

As we enter the 21st century, progressive industries have replaced or are considering replacing wood with plastic pallets and products. Their reasons are economic, ergonomic and environmental.

Economic Performance

Every major grocery distributor in North America has committed to using plastic pallets. Why? Because a plastic pallet will make hundreds of trips while a wood pallet may last only seven.

Even though the initial cost of a plastic pallet is three to four times that of wood, the per trip cost is pennies compared to dollars.

Wood pallets also need frequent repairs, often costing down-time. Some food distribution groups report that, on average, a wood pallet needs repair every 2.5 trips. By contrast, a major grocer using 150,000 plastic pallets, each making about three trips a week for an entire year, has not returned a single one as defective.

The attractive appearance of plastic pallets also saves on distribution costs by making it acceptable to move loads of goods directly to point of sale.

Better Ergonomics

Wood pallets are rough and heavy. Scrapes and cuts are common as grocery stockers, for example, guide their ankles around the jagged corners of wood pal-

lets. Muscle injuries are a fact of life among manufacturing workers who handle heavy, awkward wood pallets many times a day.

The smooth edges, soft corners and light weight of plastic pallets are worker friendly and help reduce medical costs.

plastic, however, it is often in excess of the intended application (i.e. - The wood used in pallet stringers is the same wood used to temporarily support large machinery and buildings). Over the years, this strength has been taken for granted, with the development of unit load configurations and handling equipment.

A plastic pallet with the identical shape and strength of wood is not economically practical. The first objective is to understand the effects that a different pallet shape and strength will have on the total system. Optimizing a plastic pallet's design is best accomplished through review of load configurations and pallet handling equipment. This booklet introduces plastic materials and processes, describes the features and configurations of pallets and other material handling product, and discusses areas in which materials handling equipment and operations may need modification.

We also provide here, for the first time in the industry, a set of performance ratings developed by TriEnda for plastic pallets and material handling products. Site testing instructions are also included.

The material handling or packaging professional who is considering plastic can use these measures with confidence to choose objectively among competing products.

"Productivity is only improved through improved communication"

This guideline equips the professional accurately to present plastic products to potential users and gather with essential data for application approvals.

Refer to the Application Analysis for plastic products at the back of this guide. This form can be used as a presentation outline and a data transmittal.

Environmentally Responsible

At one time about 20% of the trees cut in the US went into pallets and shipping containers. Many were one-way pallets that went to the landfill after a single use.

Times and attitudes have changed. Landfills are fewer, more selective and more expensive. People recognize that preserving trees benefits the ecology of the planet. Recyclable plastic pallets are the perfect alternative. Their long lives keep wood pallets out of landfills and when they need replacement, they can be ground and molded into new plastic products. In addition, some pallets can be made from recycled plastic, preserving even more landfill space.

Replacing Wood with Plastic

Investing in any new technology takes thought and effort. Changing to plastic pallets is no exception. Wood is relatively simple, a known quality, while plastic has its own characteristics and offers a multitude of advantages.

The characteristic strength of wood is 13 times stiffer than most

Pallet material characteristics

Wood

Familiar
Widely used
Inexpensive per unit
Fits MHI equipment
Easily worked

Needs repairs
Short lifespan
Disposable
Stiff
Heavy
Rough & splintery
Unesthetic

Plastic

New technology
Higher unit cost
Possible MHI modifications
Sophisticated manufacturing
Temperature considerations

Durable
Long lifespan
Recyclable
Low cost per trip
Flexible
Lightweight
Smooth & attractive
Easily customized

Plastic Resins and Manufacturing Processes

Resin type and production process are the two major cost factors in producing plastic pallets and other material handling products (MHP). Structural shape also determines the product's performance.

Plastic Resin Types

Polyethylene- the industry's most commonly used resin- is very tough but more likely to stretch than break. Its long, tangled, spaghetti-like molecules can be reheated and reshaped many times. A broad variety of additives can help customize product performance and aid in processing.

Polypropylene is stiffer than polyethylene but is more likely to crack in cold temperatures. Sometimes used as a stiffener with polyethylene, its most common MHP use is in totes which often must be sterilized.

Additives

Additives help tailor a material to a particular application, enhance quality, and

improve production. They must be used with care and measured with standard laboratory tests since enhancing one property may degrade another. For example stiffeners can cause brittleness:

- ✓ **UV stabilizers** reduce sunlight-caused brittleness.
- ✓ **Anti-microbials** prevent or limit bacteria, fungus and other organic growth.
- ✓ **Anti-stats** prevent build-up of static electrical charges.
- ✓ **Flame retardants** control burn characteristics.
- ✓ **Fillers** can reduce costs, lighten, and stiffen.
- ✓ **Colorants** customize appearance.

Design/Manufacturing Challenges

The challenge for design engineers and manufacturers is to find the most economical balance of resin mix, shape, and production characteristics that meets the

customer's performance expectations. Three inputs are critical: (see application analysis form on page 29.)

1. Precise information on operating environment.
2. Load types and configurations.
3. Equipment descriptions which define support conditions.

Fact File:

Postal Testing

The U.S. Postal Service conducted exhaustive studies to determine which material and process provided superior physical and economic performance in its closed loop bulk mail distribution system. Upon reviewing this section the reader will understand why USPS choose high density polyethylene as the material and twin-sheet thermoforming (TSTF) as the process to replace millions of its wood shipping pallets.

PROCESS	DESCRIPTION	CONSIDERATIONS	COMMON PRODUCTS
Sheet Extrusion	Sheets are formed in a continuous process and stored in rolls or flat sheets.	Low cost	Slip sheets
Thermoforming	Heated sheets are formed over molds. Twin sheet welds two sheets together during the process.	Low cost tooling and prototype parts High production rates Can totally encapsulate substrates	Pallets Containers Sleeves Dunnage Totes
Injection Molding	A hollow mold is filled under high pressure.	High tool costs	Totes Containers
Structural Foam Molding	A hollow mold is partially filled with plastic and a foaming agent; the mix expands to fill the mold.	High tool costs Stiffer but more brittle parts	Pallets Containers
Blow Molding	A sealed tube of plastic is blown like a bubble against the walls of a hollow mold.	High tool cost	Drums Tanks
Roto Molding	Melting pellets line the inside of a mold which tumbles on three axes.	Low cost prototypes Slow process	Drums Pallets Containers
Compression Molding	A molten billet of plastic is squashed between the closing mold halves.	Can use very stiff materials	Totes

Extrusion

The process of extrusion is when plastic resin is converted from solid to liquid. This process, known as screw extrusion, is the first step for several manufacturing processes (processes to follow). It can be described as a large continuously rotating screw inside a heated tube. Plastic pellets, powders, and/or liquids enter one end of the tube and are conveyed, melted, mixed, and pumped out in to a molding process, which form plastic products used in the material handling industry.

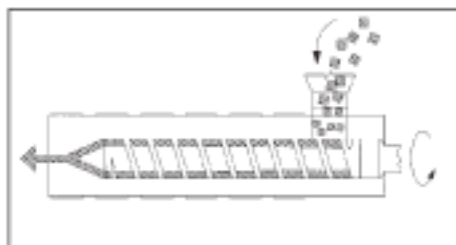

Structural Foam Molding (LPI)

Low Pressure Injection

The process of low pressure injection is when a mold cavity is filled with "expanding" foam resin under low pressure. This process is commonly used to make material handling products and is similar to injection molding. The major distinguishing difference between foam molding and injection molding is that in foam molding a foaming agent expands the resin and produces a product which has a generally smooth outer skin and a cellular core. This greatly enhances the stiffness to weight ratio, however dramatically reduces the base material to withstand the impact found in common material handling systems.

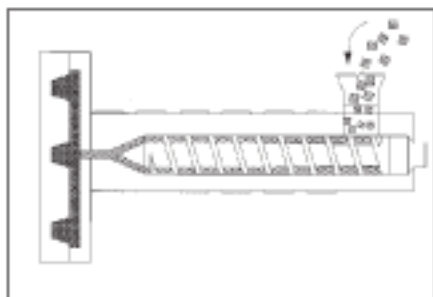

Blow Molding (BLM)

The family of products typically developed through the process of blow molding are: pallets, containers and barrels, which all share a similar design needs; hollow sections. The blow molding machine consists of one to five extruder/injector heads feeding a die. It drops (by way of gravity) a round or oval molten tube (parison) of material between two open mold halves. The parison walls may vary in thickness and can consist of several different layers of material. When the parison is in position, the mold halves are closed upon it, capturing and sealing off a section of parison, which is expanded and held against the mold walls by air pressure until cooled. The part is then removed and trimmed. This process has an advantage over twin-sheet (TTF). With blow molding, the resin pellets are processed at the machine and thereby eliminates handling and heat costs associated with producing sheets for thermoforming. The disadvantage of blow molding is it does not distribute the material in a finished part as efficiently as twin-sheet thermoforming nor can substrates be easily encapsulated for ultimate stiffness.

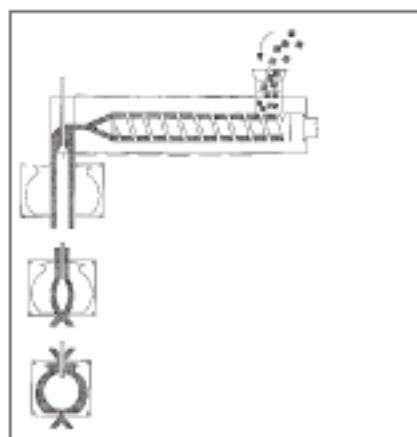

Profile Extrusion (PSX)

The profile extrusion process is used to manufacture plastic lumber used in some forms of plastic pallet construction. The thickness to height ratio distinguishes it from sheet extrusion. This process uses an extruder to force molten resin

through a die the shape of the cross section required (i.e. a 2" x 4" stringer and 1" x 6" boards). As — or before — the material leaves the die, the cooling process is initiated and continues until the extrusion is rigid enough to cut in to lengthwise strips. The large extruded cross-section allows for the use of difficult-to-process recycled consumer plastic products, however the pallet constructed of this material can weigh many times that of a wood pallet of like size and constructions.

Injection Molding (HPI)



High Pressure Injection

The injection molding process is used to make single-piece products or components used in the construction of products, such as; pallets, bins, and totes. A multiple piece mold, containing voids in the shape of the desired part, is held shut by an hydraulic press. It is then filled with molten material by means of an extruder and high pressure injector system. When the part has sufficiently solidified, the mold opens to eject the formed part. A wide variety of materials can be processed using this method and few, if any, secondary operations are required to finish the part after ejection. Typically, this process requires the greatest initial tooling mold investment.

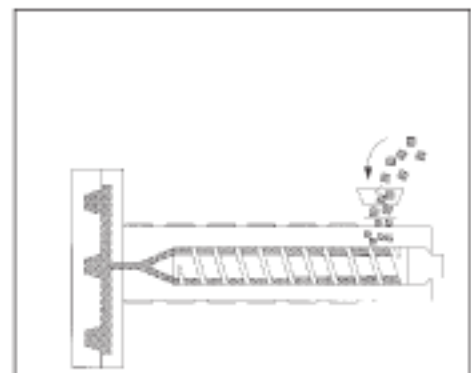

Sheet Extrusion (STX)

This process forms flat sheets used for load separators, slip sheets, and sheet stock required in vacuum forming. It is a continuous process using one or more extruders feeding a single die, which forms a wide sheet of one or more layers of different materials. The die dispenses the molten sheet onto a series of rolls. This controls the thickness of the sheet and begins the cooling process, which solidifies the material. Rolls can also be used to impart patterned textures onto the surface of the sheet. Other materials, such as stripes and printed substrate, can be combined with the surface of a molten sheet as it is fed through the rolls, forming an excellent bond. The sheet is cut to required size or wound onto a roll without interrupting the flow.

The sheet extrusion process can efficiently combine several materials, laminates, and textures into a single highly engineered sheet.

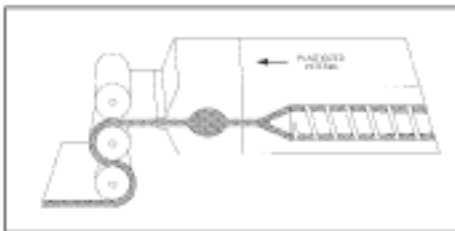

Roto Molding (RTM)

This process is used to make the same family of product as blow molding and twin sheet (TTF): pallets, barrels, and containers. Roto molding forms products by placing plastic resin pellets within a mold

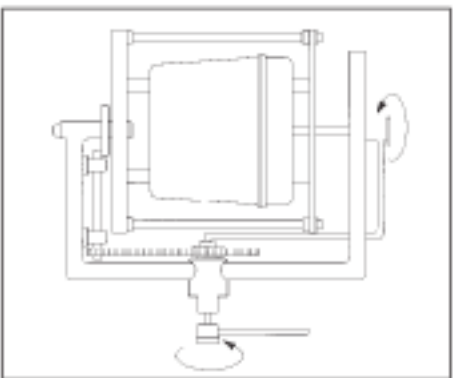

cavity, shaped to the outside surface of the desired part. The mold is rotated on multi-axis in an oven which melts the plastic and the rotation distributes it within the mold. When the plastic is completely distributed, the mold is moved from the oven to cool before the product is removed. The major advantage of this process is: low cost tooling. The disadvantage is the higher cost due to the long cycle time, and controlling non-uniform material distribution.

Single-Sheet Thermoforming (STF)

This process is when a single extruded sheet is heated and positioned over a horizontally oriented mold and sealed at its perimeter. The air between the mold and heated sheet is evacuated and atmospheric pressure forces the sheet to conform to the surface of the mold. Plugs, which help stretch the material to create vertical wall thickness, are used to optimize material distribution to critical areas. Material handling industry products, such as; pallets, totes, trays, containers, and components are manufactured using this process. Other advantages of this process include, low cost prototype parts, low cost tooling, partially encapsulated substrates, and the full range of options associated with extruded sheet.

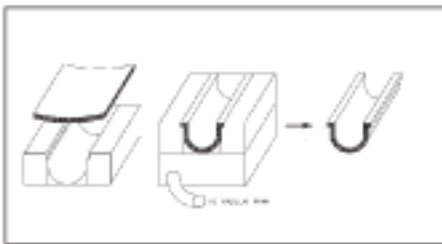

Twin-Sheet Thermoforming (TTF)

Twin-sheet thermoforming (TTF) heats two individually engineered sheets, on two individual molds, positioned horizontally; one above the other. Before the two sheets are brought together to form a single welded part, a stiffening substrate can

be positioned between the sheets, which then is encapsulated by the welding step. The large size of TTF machinery, and the high cooling capacity of twin molds, provide relatively high processing volumes. The combination of high material distribution efficiency and the ability to weld two individually engineered sheets together provide high performing hollow light weight structures. Low cost custom prototype parts and moderate cost molds are additional benefits unique to TTF. Pallets and containers are two major families of material handling products manufactured with the TTF process.

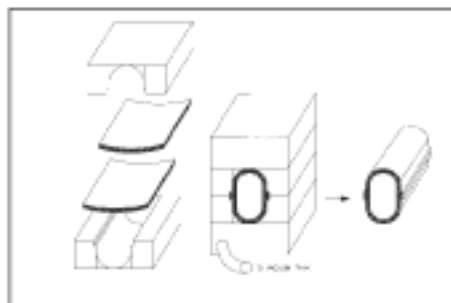

Compression Molding

A soft "blob" of material, known as a billet, is placed on a two-piece horizontal mold surface, which is mounted on a press. The mold is closed, forcing the billet to conform to the mold surface. Once the conformed billet has cooled, it is removed from the mold. The "flow" that is created due to this molding process allows for a variety of difficult materials and structural fillers to be produced with various wall thicknesses and minimum distortions. More sophisticated processes can inject general billets within a single mold for onrolled flow during compression.

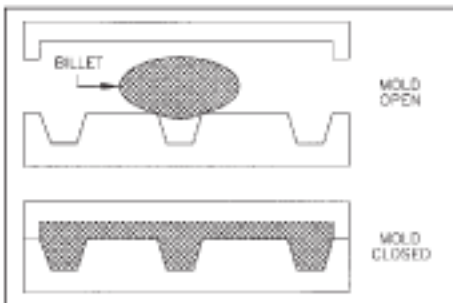

Platform, Container & Tote (PCT) Movement Within A Distribution Chain

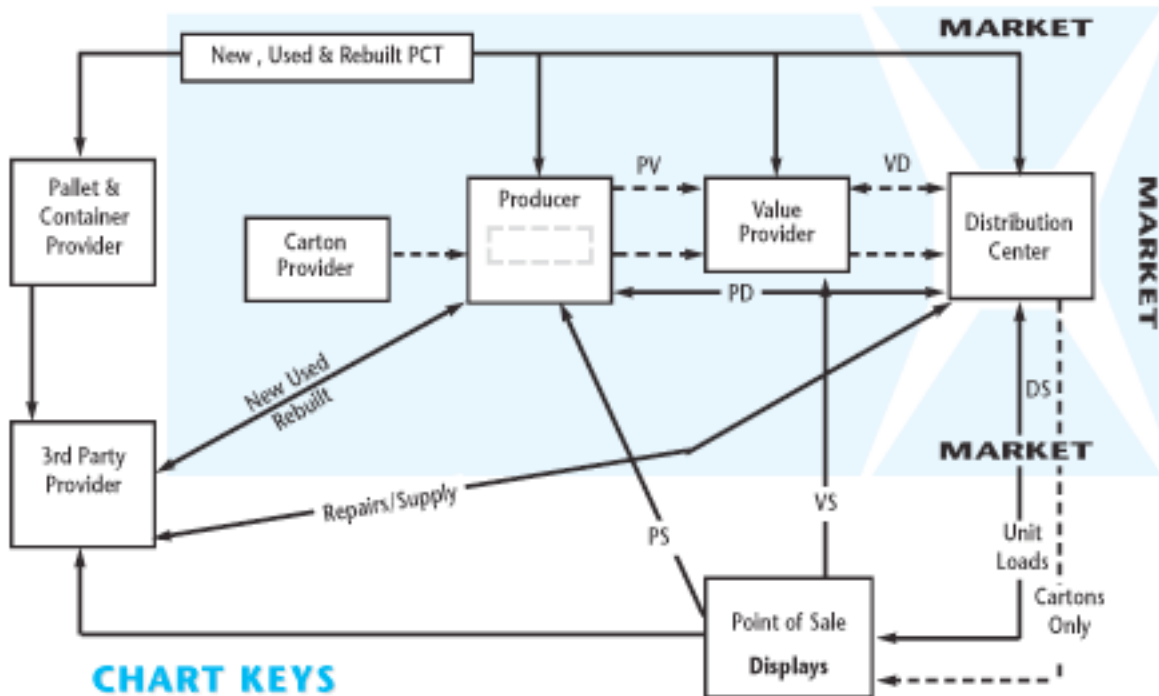

CHART KEYS

Loop Code	Facility	Storage	Notes
P	Producer	Stacks	(Few SKUs)
V	Value Added	Stacks & Racks	(Many SKUs)
D	Distributor	Racks	May Ship Cartons
S	Point of Sale	Displays	
I	Internal Use	Special Use	AS/RS Pallet

Transportation Modes	
OTR =	Over The Road
Rail =	RailRoads
Air =	Air Transport
Sea =	Ship

Original Producer: The originator of the product or component of a complete product destined for the end user. The product may be a fish, carrot, metal casting or a diamond. Producers typically tend to stack products or use High-Density storage systems.

Value Provider: A value provider receives products from upstream and adds some value to it and

Moves it downstream toward another value-added facility, distribution center or directly to the end user. It may be an assembly facility, packager, warehouse or bakery. Value providers may need to access many different items so may employ rack systems as well as stacking for storage.

Distribution Center: The Distribution facility is often the last facility. The product interfaces with before the point of sale. Distribution centers usually ship product downstream using PCT, cartons or both. Some ship-

ments may go direct to user while others ship to Point of Sale facility. DC's may interface with several different markets and must facilitate the requirement of those markets. (i.e. food, perishable or auto)

Point of Sale: The majority of product at a Point of Sale facility is on display for end user purchase. Some selector rack may be in use but the objective of the facility is to display and rely on the DC for supply.

Internal Loop: PCT may serve some special function within a facility, usually for facilitating a special processing or storage concern within the facility.

Trip Loop: The defined movement of PCT. When the term trip is used it usually has associated with it a breakdown of handling, when loop is used it is often a vague term. Definition of trip loop is important to estimate "Trip Life" (the total number of trips a product can com-

plete).

Loop Float: The total number of PCT within a trip loop required to maintain a given service level. Float size calculations vary with industry and customers.

Transportation Modes: PCT unit loads are transported a variety of ways. Each subjects the PCT and load to different conditions. These conditions should be understood by practicing professionals.

PCT Provider: A manufacturer or supplier of PCT may vary the construction and basic material to meet requirements of different markets. Paper and corrugate providers are not included in this description.

Third Party Provider: Usually rents or leases PCT products to facilities. And/or provides other logistics services.

Plastic material handling products fall into three families: platforms, containers and totes. It is important to become familiar with these categories because they will be referred to often in upcoming sections.

Most goods shipped in the logistics industry use platforms, containers and totes as their primary shipping product. And the products in these three families can be conveniently combined into one unique product for ease in the logistics industry.

The first family — platforms — generally described as having a simple shape, provide protection and good mechanical handling interface with other shipping products (i.e., slip sheet, pallets, dunnage trays).

Containers, the second family, is volumetric in shape and also provides good mechanical handling equipment interface (i.e., sleeve pack, IBC and insulated container). The third, and final material handling family, totes, is designed to be manually or mechanically handled.

Each family offers a wide range of product features and options for the markets they serve. Auxiliary products, such as sleeves and load caps, enhance the performance of platforms, containers, and totes.

To follow, are brief descriptions of common products within the three families. At the end of this unit there is a process/product distribution matrix. The *Common Products Options* matrix matches products with important material handling features as they relate to specific markets.

9 Post Nestable (9N) 4x4 entry*

Normally molded as a single piece with nine posts or legs. Corresponding pockets in the load deck facilitate partial or complete deck-to-deck nesting. Nesting cuts volume for more efficient pallet storage and transportation.

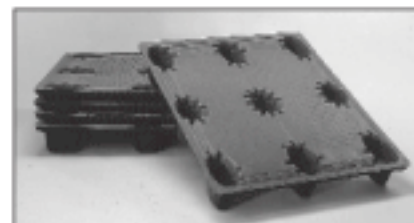

3 Stringer (3S) 2x4 or 2x2 entry*

Normally molded as a single piece with three stringers and a continuous load deck surface. The continuous deck maximizes support of the unit load. When pallet is stacked on another unit load, the stringer bottoms cut stress by distributing weight over more area.

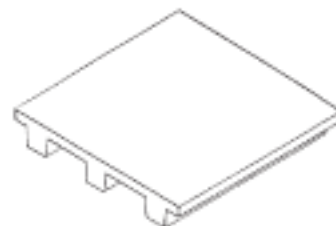

3 Runner Pallet (3R) 4x4 or 2x4 entry*

Uses several components to configure a pallet with three runners attached to nine posts (legs). Offers improved support in racking, conveying and stacking. Runners can be in length or width.

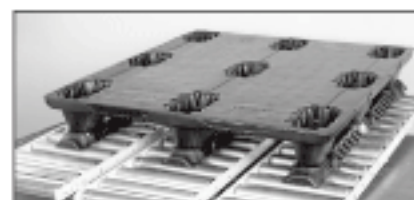

Pallet truck entry is usually parallel to runner making it very unlikely that damage will occur relative to load wheels extending.



Reversible Pallet (2D) 4x4 entry * (usually)

Often uses two similar molded pieces joined so either deck surface could be the load bearing surface while the other is the interface surface. Uses several components. This configuration



*4x4, 2x4, 2x2 entry: The first digit is the number of sides a pallet jack, with a 3-1/4" height requirement, can enter. The second digit is the number of sides a lift truck, with a 2" height requirement, can enter.

5 Runner Pallet (5R)
4x4 entry* (usually)

Uses several components. This configuration has two runners positioned perpendicularly to a set of three runners. In plastic pallets the five runner surfaces are often a single attached (and replaceable) piece.



6 Runner Pallet (6R)
4x4 entry* (usually)

Same as 5 Runner Pallet except that two sets of three runners form a grid-connecting all nine posts.

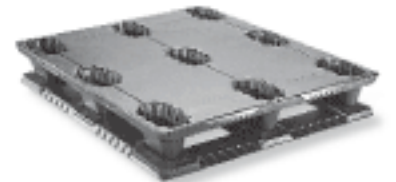

System Pallet (SP)

Designed to provide a consistent interface with machinery used in automatic storage and retrieval systems (ASRS). ASRS's fall into two categories (pallet features vary to accommodate each):

Manufacturing—This pallet meant to be used from manufacturing through assembly. It's designed to hold a part as it moves from one manufacturing step to the next and between facilities as the part is assembled into finished product (i.e. automotive pistons & seats).

Storage—Designed to act as a platform for various size pallets or containers, which rest product while being transported or stored.



Unit Load Cap (9C)

Formed as one piece. It can be banded, belted or affixed to a unit load. This helps maintain and protect the load by providing a platform on which to stack other pallets. It also protects the load from damage due to banding. Often used with 9 post nestable pallets when stacking with loads. (cap shown with pallet sleeve below right.)



Pallet Sleeve (KT)

Used with pallet and cover to form a container that protects packaged product, loose products, or produce. Some pallets are designed to double as covers.

Pack Dunnage (PD)

Positive Weight Transfer (PT)
No Weight Transfer (NT)

Pack Dunnage may be shipped on a pallet or in a container (see bottom of page). This type of dunnage usually consists of separator trays shaped to position a part in a tray to avoid damage and sometimes facilitate robotics. The trays are single or twin-sheet design. Depending on the requirements, there are two basic types:

- **Positive weight transfer** — Trays use the parts to support the weight of the trays stacked upon each other.
- **No-weight transfer** — Trays are used when parts are too fragile to bear weight without damage. This type of tray is often more expensive than positive transfer trays.



Rack Dunnage

Separator (SR)
Book Leaf (LR)

Rack Dunnage — Commonly used in automotive and other metals manufacturing. Plastic components are fastened to customers' metal rack systems.

Separator Rack — Dunnage (see photo right) is generally less expensive than Book Leaf Dunnage. SR parts can be quite long so adequate compensation for thermal dimensional changes should be provided.

Book Leaf — Formed plastic dunnage that is hinged & fastened to a rack. Each piece of hinged dunnage protects like a page in a book. Opening each "page" allows parts to be placed between dunnage creating protection and easy retrieval.

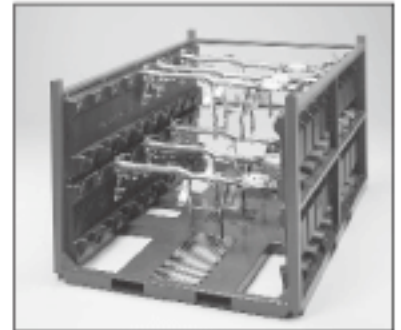

Tote Bin (TB)

Tote Bins — Usually handled and used for storage and transport product, they can be molded as a single piece or in multiple pieces to achieve stacking or knockdown benefits.



Container (CP)

This product is often mechanically handled. It can be molded as one piece or with multiple components to achieve knockdown benefits. Fork and pallet truck clearance is usually provided and bottom runners are often incorporated.



Slip Sheet (SS)

A flat sheet available in a variety of materials, which may contain only two features; size and thickness.

Common Product Options

Pallet options are intended to reduce the initial cost or cost of use. (i.e., color provided lower labor cost for sorting or identification)

Tracking & Security

	Grocery Distribution	Retail Distribution	Food Producer	Automotive	Pharmaceutical	Electronics	Beverage	Air/Sea Transportation	Printing	Pallets	Containers	Totes	Sleeves	Loadcaps	Slip Sheets	System Pallets	Pack Dunnage
TS Stripe	X	X	X	X	X	X	X	X	X	X	X	X	X	X	X	X	X
TC Color	X	X	X	X	X	X	X	X	X	X	X	X	X	X	X	X	X
TL Labels			X	X				X	X	X	X	X				X	
TH Hot stamped graphics	X	X	X	X	X	X	X	X	X	X	X	X	X	X		X	
TG Silk screen graphics	X	X	X	X	X	X	X	X	X	X	X	X	X	X		X	
TE Encoder								X		X	X					X	
TL Logo	X	X		X						X				X		X	X
TT Security TIE/Seal											X	X					

Load stabilizing

SB Band groove										X						X	
SL Sleeve lock				X						X				X	X		
SR Retaining belt				X						X							
SS Surface										X						X	
SC Cargo lip				X						X					X	X	
SG Sleeve groove	X		X	X	X					X				X			

Functional performance

FA Anti-static						X				X	X	X	X	X		X	
FG Gate							X				X						
FT Gauge				X						X							X
FJ Anti-jam (nesting)										X	X	X					X
FC Leg opening cover			X				X			X							
FS Substrate										X			X			X	
FN Stack/nest																	X
FL Alignment																	X
FF Flame retardant	X	X								X	X	X	X	X			
FM Anti-microbial			X							X	X	X	X	X			
FD Dust Lip																	X

Anti-slip/skid

AP Grip Lock Plus	X									X							
AL Grip Lock	X									X							
AD Anti-Skid Device	X	X								X	X						
AT Textured deck	X									X							

Equipment interface

EN Rack notch		X								X	X						
EG Machine grip		X		X	X					X				X	X	X	X
EI Index									X				X		X		
EW Wings (double/single)							X			X							
E2 Entries: 2x2	X	X	X	X	X	X	X	X	X	X	X						X
E3 2x4																	
E4 4x4																	

Air/gas/fluids

RV Ventilation			X							X	X	X	X	X			
RD Drain holes										X							X
RC Leak containment										X							

Ergonomics

GH Hand holds										X			X	X	X	X	X
---------------	--	--	--	--	--	--	--	--	--	---	--	--	---	---	---	---	---

Features and options not available on all products.

Assessing Material Handling Equipment

Currently most material handling (MH) equipment, such as; lift trucks, storage racks, conveyors, etc. are designed for wood pallets. When choosing plastic pallets and other plastic material handling products it is important to carefully evaluate and measure all system elements to ensure proper function and fit.

On the following pages are illustrations of the common MH system components. Use these to identify the critical dimen-

sions (marked with letters and arrows). Measure the dimensions and record the information on the "Application Analysis Report."

Challenges accompany some illustrations. These are recommendations for methods to modify existing MH equipment to better accommodate the differences between wood and plastic. They can also be used with equipment suppliers to consider features and options on future equipment.

Functional Differences of Plastic

It is important to understand stiffness, weight, friction and accessibility characteristics when considering the handling of plastic pallets with equipment designed for wood.

Some characteristics affect only one or two types of equipment, while all or most of them are considerations for other equipment types.

The following info box lists common differences, situations and equipment often associated with equipment. All of these concerns can be overcome by designing equipment to accommodate plastic pallets, containers & totes.

- ✓ **Stiffness** Most plastic pallets are less rigid than wood. They may sag more when carrying loads on unsupported spans.
Lift trucks, pallets, racks, gravity conveyors, ASAR components, AGV, truck/trailer body floors
- ✓ **Weight** The significantly lighter, empty, plastic pallet can bounce during transportation. It may vibrate off the inclined surfaces or have insufficient weight to un-nest by gravity.
Lift trucks, pallet trucks, dispensers
- ✓ **Friction** Unit load components generally slide more easily on untreated plastic pallets. This may be an advantage to a stock picker who manually slides boxes around the surface to adjust the first few layers. It may be a disadvantage when shrink-wrapping a light load.
Lift trucks, slides, dispensers, shrink wrappers
- ✓ **Accessibility** Vertical supports on most wood pallets are 1.5 inches wide. Plastic vertical supports of this dimension can be weak but wider supports, while much more durable, reduce the size of the fork opening. Measure and record these critical dimensions using the following pages for reference.
Lift trucks, pallet trucks, racks, dispensers
- ✓ **Combustion** The combustion characteristics of HDPE differ from those of wood. They are both organic in composition and have several similarities, (i.e.: both materials burn and release water, carbon monoxide, and hydrogen chloride). Typically polyethylene requires higher temperature to ignite vs. wood, but once it is burning, polyethylene releases more heat.
Note: Call TriEnda for current fire related information regarding plastic.

Storage Racks

The major concern with most storage rack systems is the shape of the support surfaces which interface with the pallet, and the location of those surfaces in relation to the pallet.

▶ Drive In/Thru Racks (RD)

Allows very dense storage by allowing access to pallet positions with a minimum of floor space devoted to aisles. The pallet support is often a continuous surface so pallets slide into racking system.

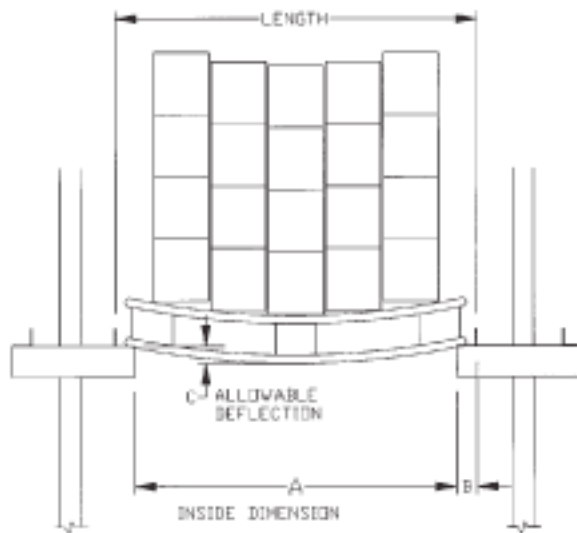

▶ Push Back Racks (RP)

Use incline roller systems to advance the last unit load to the aisle. Additional unit loads are stored by pushing back the last unit on the roller system.

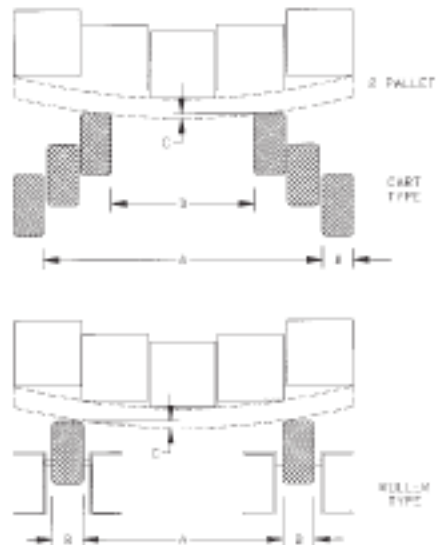

CHALLENGE: A third set of rolls reduces the clear span permitting the use of lower cost pallets.

▶ Selective Rack (RS)

Probably the most common system, allows easy selection among a maximum number of different items.

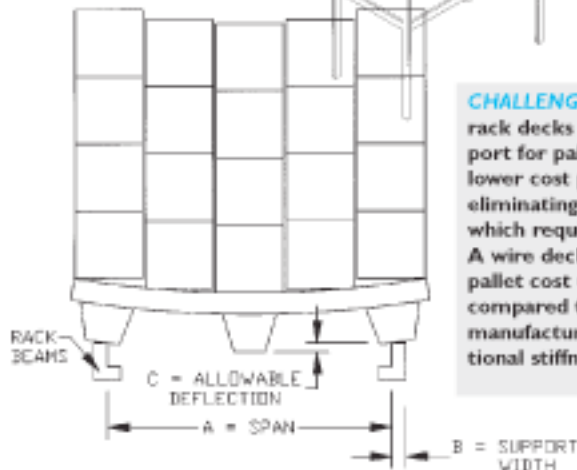
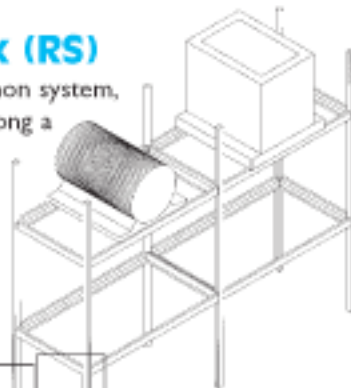

CHALLENGE: Adding rack decks or other support for pallets allows for lower cost pallets by eliminating the span which requires stiffness. A wire deck can reduce pallet cost up to 30% compared to a pallet manufactured with additional stiffness.

▶ Flow Racks (RF)

Pallets are placed on the raised end of the rack, and roll forward, making room for another pallet (rolls vary in configuration).

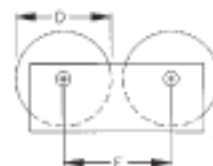
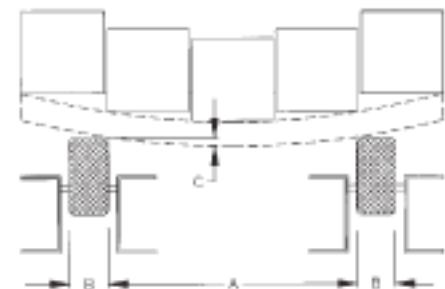

CHALLENGE: Adding a third, middle, set of rolls greatly reduces the structural requirements (cost) of a plastic pallet. Most of the load is on the middle of the pallet so the middle set provides greater support.

Transports

This analysis of equipment deals with the support of goods on pallets during transportation between storage/distribution facilities, and truck, rail, ship or air transports.

► Lift Trucks (TL)

Various styles engage pallets with forks which can have fixed or adjustable positions. They can be placed in two categories: trucks which must straddle the pallet (S) and non-straddle (N) usually counter balance trucks.

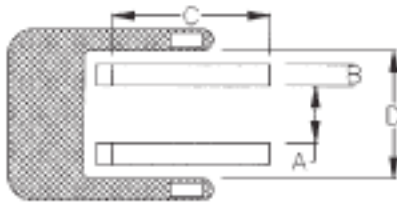

STRADDLE TRUCK (S)

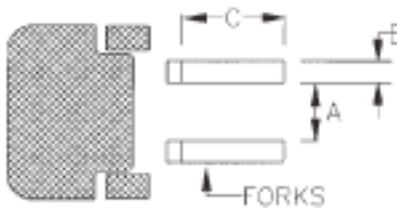

COUNTER BALANCE TRUCK (N)

CHALLENGE: The optional top chamfer on lift truck fork tips double the chances of cutting plastic pallet legs. Transport plastic pallets with forks' tipped back.

► Automatic Guided (TG) Vehicle

As a means to transport pallets with routing instructions supplied directly from a computer. Methods of pallet engagement and support vary.

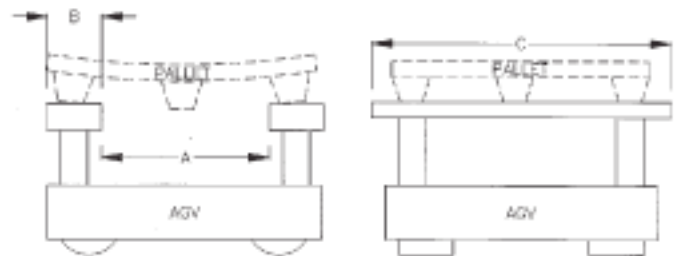

Notes:

► Pallet Trucks (TP)

Are used to lift the pallet off the floor for transport while loading/unloading and relocation. Typically the lowered height at load wheels is 3.25 inches.

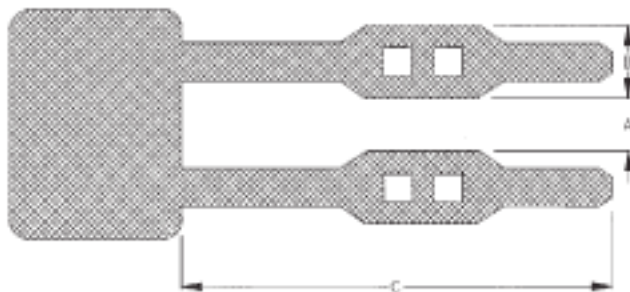

CHALLENGE: Adjusting lift linkage geometry so that the raised position results in the forks sloping toward the rear or adding rough surface treatments to fork surface will prevent the light weight plastic pallet from slipping off while transported empty (especially freezer applications). Reinforced forks should not reduce pallet access.

Conveyors

Conveyors which traditionally move wood pallets can experience difficulty in efficiently moving plastic pallets which are lighter, smoother and less rigid. In the systems which cannot be modified, the pallet can be customized for better integration. Automatic storage/automatic retrieval (ASAR) systems are often combinations of conveyors, storage racks and lift truck interface equipment.

▶ Belt Conveyors (CB)

Are often used on inclines where roller surfaces have insufficient grip. Smooth plastic pallet surfaces can be treated to increase resistance to slip.

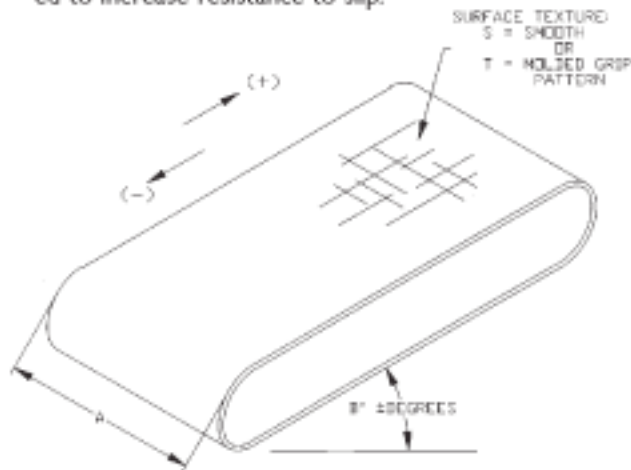

CHALLENGE: Select belts with molded grip patterns to facilitate untreated less costly plastic pallets.

▶ Chain Conveyors

Usually consist of two strands of chains which support the pallet. They vary in width, style and length. Short conveyors, sometimes called transfers, move pallets from one conveyor to another.

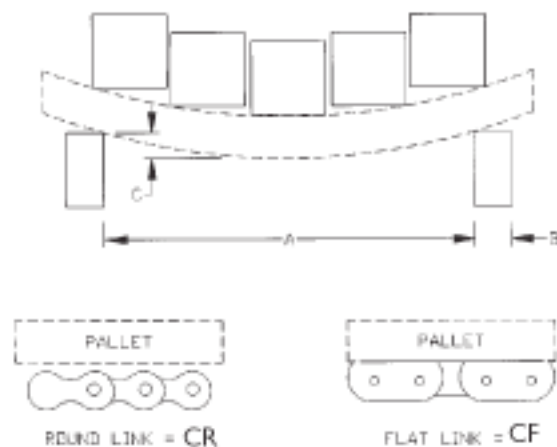

CHALLENGE: Wide flat link-style chains are less prone to wear grooves in pallets. A third "center" chain reduces the chance of interference due to pallet sag.

▶ Roller Conveyors (CR)

Can be powered on gravity and consist of a single full width roll or multiple rollers on the same axis.

Single Width Roller = W Multiple Width Roller = M

Skate Wheel Rollers = (Indicate the number of wheels on shaft)

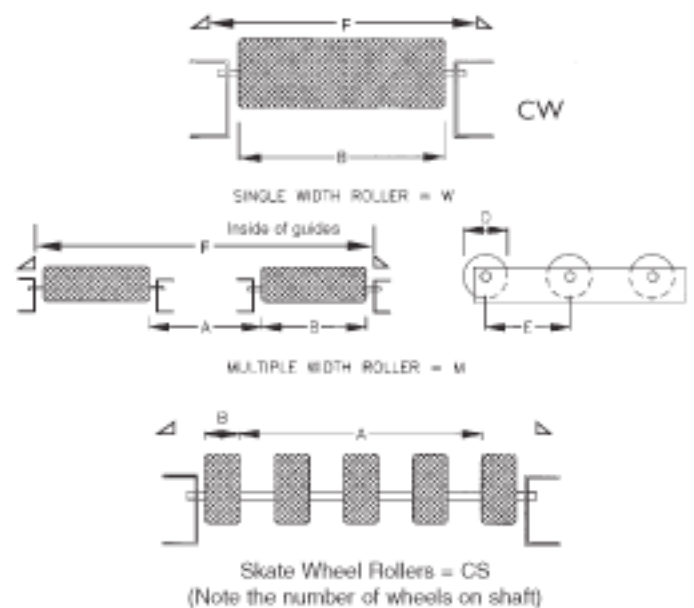

▶ Ball Transfer (CA)

Often used in aircraft holds and custom equipment, they are omni-directional in conveyance and are easy to install. The small contact area penetrates plastic more than other types of conveyors and as a result moves with more effort.

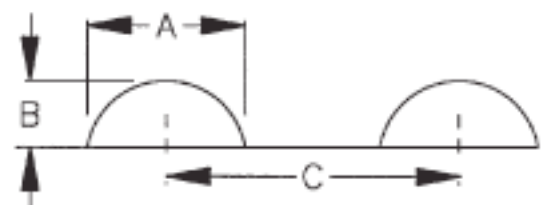

Other Pallet Equipment

When pallets are not bearing loads, they must interface with other facility equipment.

Slides (CI)

An inexpensive device which can be used in returning empty pallets- smooth pallets can accelerate to high speeds. Stopping the pallets at the base of a slide becomes a major concern.

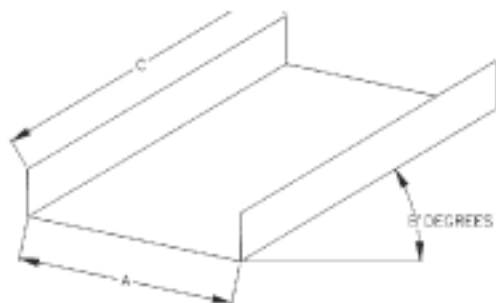

Lift Slings (CG)

Often required by the Military, lift slings pose significant concerns with plastic pallets. They can deform contact surfaces or slip off smooth rounded edges.

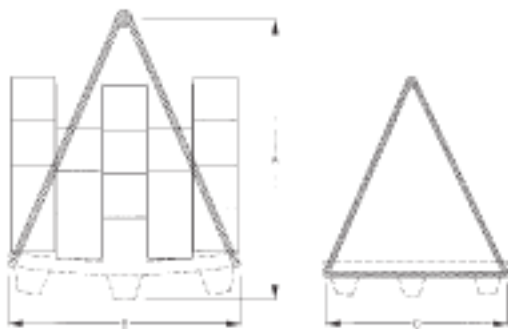

CHALLENGE: Gravity is sometimes insufficient to separate light weight plastic pallets which nest to save space. An additional mechanism should be employed to assure pallet separation.



RETRACTED POSITION FOR PIVOT STYLE PALLET SUPPORTS

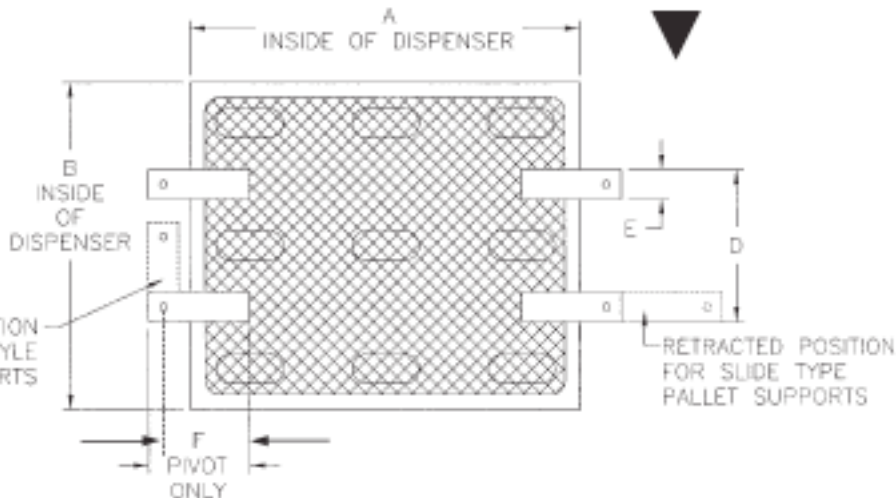

Load Transfer (ET)

Are used to slide the unitized load from one pallet (or slip sheet) to a plastic pallet. Plastic pallets must be carefully aligned to prevent damage.

Reefer Trailers (ER)

Smooth plastic pallets slide more easily on aluminum floors which were designed for wood stringer pallets (Not required for Post Pallets). Reefers must often back down steep slopes and stop with a jar a many store receiving docks. Effective load restraints for stacked frozen goods (slippery sue to frost or plastic packaging) are recommended.

CHALLENGE: Specify continuous surface aluminum floors with surface texture (to retard slippage) and two sets of "E" restrain hardware installed on each wall at uniform elevations so standard restraining systems can be used and less labor intensive ones can be developed and standardized.

Pallet Dispensers (EP)

May be stand alone pieces of equipment or may be integrated into systems. Empty pallets are stored in vertical stacks and can be dispensed from the top or bottom of the stack depending on design. Bottom dispensed units usually rely on gravity to separate the dispensed pallet, while retractable "dogs" support the remaining stack. Retraction is accomplished by pivoting (horizontally or vertically) or by sliding support dogs. Pivoting requires more room from pallet space.

Plastic pallets entered the material-handling industry in a wide variety of designs and materials. There were many competing performance claims, and few standards for evaluating them. Terms used for wood pallets, such as static and dynamic, were inadequate and sometimes inappropriate for measuring plastic's performance. Labs, which determine static

and dynamic ratings use different test methods. And, manufactures often publish the most optimistic data, which often is unrealistic.

TriEnda, whose primary business is manufacturing plastic material handling products, began developing useful rating methods five years ago. Through customer interviews, international literature review,

and in-plant research, TriEnda designers developed the industry's first set of standardized performance rating tests.

Eight ratings used in TriEnda's test methods are: floor, fork, rack, conveyor, slip resistance, durability, pack (ratings for pallets converted to a package,) and life cycle (derating considerations are also addressed).

Floor Rating

This rating addresses situations where the bottom of a pallet is fully supported. Often pallets with loads are stored on the facility floor, stacked upon each other, and remain in that position for months or years. This can create considerable stress on the bottom pallet. Pallets may also rest for shorter periods of time on trailer floors and stacked upon each other but limited in height due to trailer confines. The limits a trailer places on the overall stack height, hence providing the less static stress on the lowest pallet, is offset to some degree by the dynamics of over-the-road transportation.

Experience, thus far indicates that thermoformed plastic pallet failure is more likely to occur to a bottom pallet stacked in a facility where several unit loads are stacked upon each other for a long period of time. Rather than during truck transport in a truck trailer (This experience could change as usage experience increases).

Performance Recommendations

TriEnda's performance rating addresses: equipment access and product clearances while bearing rated loads—all without product damage, pallet failure or creating safety hazards.

The standard TriEnda clearances are 3.25" height for pallet trucks, 2" for fork tines.

Test Methods

TriEnda's pallet performance abilities are tested and measured to perform by maintaining the rated load distributed through an air bag or other means for a period of 96 hours at 72°F in a special machine which collects data (measured in pounds) at regular intervals.

Application Considerations

The primary factors which affect the satisfactory performance of the product are those which affect equipment engagement clearances, increased side clearances due to sidewall bowing and loss of supports which cause product damage.

- Temperature of working pallet environment
- Load amount and type of distribution
- Floor conditions: Static (facility) or dynamic (transport)
- The available volume for sidewall bow
- Equipment: minimum clearances required (typically 3.25" for pallet jacks and 2" for fork tine)
- Products or packaging ability to bear loads
- Product packaging ability to tolerate uneven deck surfaces
- The area of contact the product makes with pallet surfaces. (Plastic cap of beverage bottle, end of steel drum) etc.
- Consequences of a tilted column of stacked unit loads due to pallet collapse

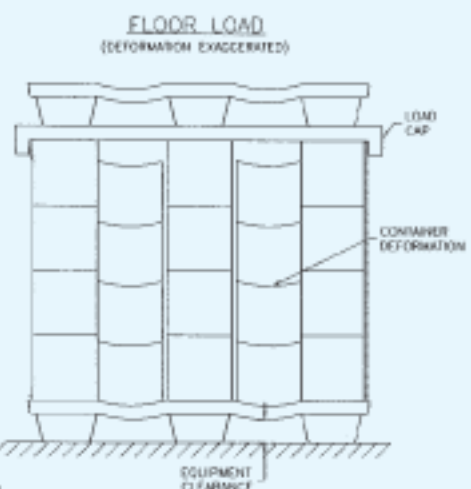

Fork Rating

Pallets are supported by lift truck fork tines as its load is moved between a loading dock and storage area. A pallet may be suspended in this condition for three or more minutes: Powered pallet trucks may support a pallet (being hand loaded) for about 20 minutes.

Where ever a pallet is being supported by forks a portion of it overhangs the outside edge of the supporting fork surfaces. The overhanging edges deflect, destabilizing a portion of the load. The orientation of pallet to forks can affect the amount of overhang and resulting destabilization. Less stable loads must be transported with greater care, usually at greater costs.

Performance Recommendations

The initial cost of the pallet must be compared to the cost of use. A lower cost pallet may not provide the stability required for high speed handling so initial savings are lost to increased handling costs. While supporting a 25 column stacked load for three minutes at 72°, TriEnda recommends a maximum allowable deflection of 1.50°.

Test Methods

No national or international standards directly address test methods nor recommend performance in this mode. Some industry groups are developing recommendations for test methods and performance values.

TriEnda tests the pallet by duplicating actual conditions and/or simulating conditions with laboratory equipment. Typically the pallet is stressed in a special compression machine using an air bag to distribute the forces. Computerized instrument's record pallet deflections using load and time intervals.

Application Considerations

The primary factors which affect plastic pallet deflection are:

- *Load weight distribution* (column or brick stack).
- *Temperatures over 120° F* can significantly reduce strength. Trailers can reach 140° F in the Southern & Western US .
- *Pallet overhang*. Like wood, plastic creeps, but often at a higher rate): most creep occurs in the first minute.
- Thus fork penetration into the deck surface (see illustration): Some pallet designs are softer or weaker in the fork support areas. These pallets must be transported slower to accommodate destabilizing forces which occurred during movement.
- *Cargo characteristics* Very weak pallets can deflect to an extent where fragile cargo could sustain damage.

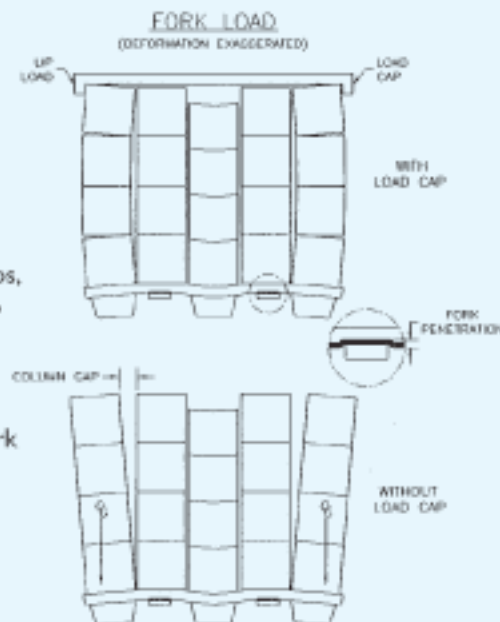

Rack Rating

Rack systems are designed to balance storage density with accessibility. Three popular rack systems are: drive thru, selector, and gravity feed racks. These and other rack systems may be combined into a total material storage system. The total system will also include manually operated (lift trucks) and/or fully automated machines to place, transport, and retrieve pallets from the rack systems. Tall dense storage facilities can also have a minimum climate control requirement. The size of the fork entry window can directly affect the time and cost of retrieving pallets from storage racks.

Performance Recommendations

Accessing pallets in a tall rack system, while the operator is at floor level, can be slow. Automatic fork positioning equipment can have a plus-minus toler-

ance of 0.5". This tolerance, plus a 1.5" inch thick fork, plus allowing a 0.25" construction tolerance to top and bottom clearances suggest a minimum fork window of 2.75". TriEnda rates pallets by determining the maximum, evenly distributed load a pallet will bear over a specified clear span while supported by 1.5" wide members at 72°F for 12 hours without detrimental damage. This rating considers the compression of supports (legs, posts, stringers) as it relates to the fork access window. The pallet must also bear a 150% load under same conditions without sustaining detrimental damage. National and international standards suggest limiting deflection based on percent of clear span but do not factor the accessing cost caused by limited fork entry window.

Equipment clearance by one industry study suggests that deflection should be limited to 0.5" regardless of span.

Reducing deflection beyond practical limits adds cost which may not be offset by other feature values (i.e. longevity, etc.).

Test

Most standards prescribe flexing the pallet deck in several positions using two supports: rack beams and two line loads. This method is simple for comparative purposes but does not distribute the load and fails to create deflection data which can be more directly correlated to user requirements.

TriEnda's test methods use an air bag in a special test machine. This machine evenly distributes a load across a pallet deck while it records load deflection and time values. These values relate to fork entry window and equipment clearance.

Application Considerations

The major consideration is most likely the pallet's ability to minimize deflection while safely supporting a unit load over clear spans, such as rack beams, conveyors, and other mechanized equipment—which does not fully support the pallet. As the pallet is suspended, the resulting deflection decreases the fork-entry window (making access more critical) and decreases the available equipment clearance. If equipment clearance is not maintained, mechanized systems can shut down resulting in great costs. The following considerations should be evaluated carefully in cooperation with the pallet manufacturer:

- Allowable equipment clearance
- All unsupported spans and time on span
- Temperature ranges (temperature affects pallet stiffness)
- Load amount and type of distribution
- Type of equipment used to access pallets

Reduced fork-entry window and system interference are the two major considerations in pallet selection and design.

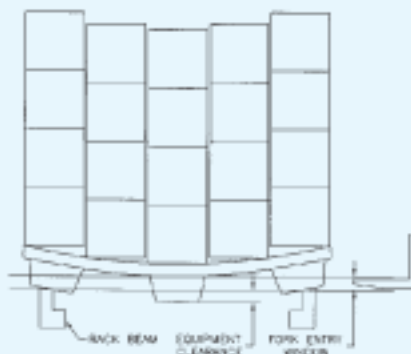

Conveyor Rating

Mechanization reduces labor costs and increases efficiency. Pallets handled with automation must have consistent quality and shape. Conveyors can be hard on wood pallets because the high-point load, and vibration of rollers. Wood irregularities are also aggravated. For example, wood knots loosen and fall out, wood splinters and break off. Nails loosen, allowing boards to hang and catch on equipment. Wood debris lodged in automated equipment could shut down some or all parts of an equipment system, creating a mechanical system failure.

A visitor to an automated facility which uses plastic pallets often notices the absence of wood debris beneath roller conveyors. The toughness and consistent quality of plastic pallets are particularly beneficial to the operating cost of mechanized systems.

Powered conveyors tend to have full width rollers with a high degree of pallet movement. By contrast, gravity conveyors, (especially in push back systems and gravity pick stations) tend to use rollers which

do not offer full support—a challenge for pallets which may sit stationary on rollers for a longer period of time. These two conditions make interfacing gravity systems and pallets more difficult to satisfy. The basic expectation of a gravity feed system is an under-strained pallet should begin rolling. If it doesn't, personnel maybe tempted to compromise their safety to initiate movement. As with wood pallets, rollers with inadequate support, can dent the contact surfaces of the pallet over time this will increase the force required to initiate movement. Increasing the slope creates higher initial force but also produces higher speeds which upon stopping can upset the load. Shock absorbers and brakes are sometimes employed to control this shock.

Performance Recommendations

Familiar national and international standards do not address conveyance issues. TriEnda focuses on gravity roller systems

and recommends that after bearing a stationary rated load for 12 hours-on a 2" diameter, full-support roller, spaced on 4" centers—pallets will roll freely on a 3.5% grade.

Test Method

A pallet, with an evenly distributed load is arranged on a tilt table using a 2" diameter full-supported roller, spaced on 4" centers. At the end of the 12 hour conditioning period, the table is tilted at a constant rate until pallet movement has occurred. The slope at which movement has occurred concludes the test results. The goal for a product design is 3.5%.

It should be noted the factors which affect the initiation of movement in actual gravity systems are so varied (i.e. quality of roller bearings and eccentricity) it is not practical to anticipate all applications.

Application Considerations

The focus is on pallet performance on rollers. Both powered roller conveyors and gravity conveyors both using a slope, have common considerations:

- Slope of roller bed
- Diameter, face profile, length, spacing, and arrangement of rollers
- Temperature of pallet (affects rolling effort)
- Load amount and distribution
- Type of physical guidance and contact
- Operation requirements of non-contact equipment (i.e. scanners, photo devices, imprinters, etc.)

CONVEYOR ROLLER LOAD
(DEFINITION ENHANCED)

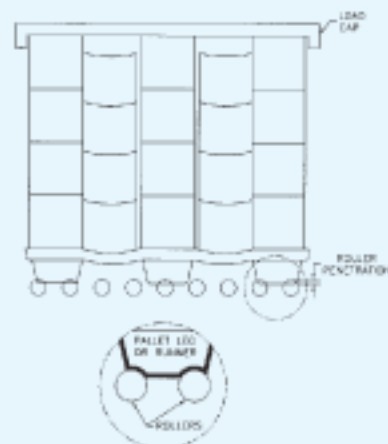

Slip Resistance Rating

Transporting a unit load induces centrifugal (center) acceleration and vibrating forces. These movements tend to cause the load to shift on the pallet deck and/or the pallet to shift on its support surfaces, which may cause accidental damage or injury—resulting in a loss of efficiency and profit. The slip resistance (SR) or co-efficient of friction (CF) are addressed several ways to suit the individual applications, such as:

- add on rubber anti-skid device (rubber pad)
- spray on anti-skid surface
- laminate surface
- mold in surface features

To maintain adequate interface, each pallet surface—which is in contact with a

load and handling equipment, must be evaluated for its suited application. Shrink wrap and/or banding are often used to retain load position.

Note: When a pallet with corrugated boxes tip, the boxes usually slip on each other before they slide on the pallet.

Performance Recommendations

Industry recommendations are very few and begin at .15 CF. Much research must be completed before practical and general recommendations can be made.

Test Methods

Coefficient of friction testing equipment is usually sophisticated laboratory-type equipment. Data gathered in the lab is often hard to collaborate in the field. Mostly we follow the Japanese test method for determining relative (SR) values. Our method uses a tilt table and adaptive apparatus to simulate conditions of the three pallet surfaces. With the rated load evenly distributed on the test pallet the table is tilted at a constant rate until the pallet slides. The angle, at that point, is the result. This roughly correlates to static coefficient of friction (the tangent of the angle) values.

Application Considerations

The three surfaces considered are: load surface, fork contact surface, and pallet support surface. Major factors which consider effect slip performance are:

- Surface conditions, (i.e. ice, snow, water, oil, etc.)
- The type of materials in contact, (i.e. plastic to plastic, plastic to wood, etc.)
- The hardness and texture of the contacting surfaces Pallet surface features and textures (molded or sprayed on) are designed to penetrate softer surfaces, such as; paper, cardboard, wood, etc.
- How much Slip Resistance SR is required?
- When SR Prevents personnel in distribution centers from manually sliding the boxes into final position on the pallet it adds cost to distribution. However, pallet retention to fork tines seems to have no limit.
- Pallet support material: metal shelving, metal trailer bottoms, new trailers with smooth new wood surfaces.



Durability Rating

Pallets must endure the rigors of normal handling. The definition of abuse will vary with each situation. Abuse is not so much associated with a particular handling method, but with how that method effects the life of a pallet. Throwing a wood pallet to the floor from the top of five foot high stack may be construed as abuse, because it aggravates existing flaws or loosens joints. However, when certain molded plastic pallets are handled in the very same manner and experience no ill effects, (due to its one piece construction and resilient material) throwing may become a normal handling technique—reducing worker fatigue. Some handling techniques require shoving a pallet with fork tips to re-position before engagement from another direction. The end profiles and faces of fork tines and pallet trucks create very high local stress which can easily damage pallets, this may be

considered a rough handling method.

Performance Recommendations

Industry in general has no recommended durability performance levels for plastic pallets. TriEnda expects that a plastic pallet loaded with the rated load will endure the low speed impact of a powered pallet truck and the reposition (rotation) using fork tips on the pallet surfaces. These should be accomplished without material breakage or loss.

Test Methods

TriEnda uses some of the same test methods used to determine the durability of wood pallets to assess durability of plastic pallets. The rating is established by the height of a corner drop test (similar

to ASTM 1185) and the ability of a pallet, bearing the rated load to be impacted by a 1500 pound powered pallet truck traveling approximately one mph. The corner drop test is measured height/inches and the pallet truck impact is measured inches/second.

Note: Our design procedure designates the material on the perimeter of a deck as an impact zone and uses a design strategy for material behavior to tolerate anticipated impact methods and levels.

Note: Most common form of detrimental pallet damage is cut legs due to fork tips.

Application Considerations

The dock area is the facilities most likely area for damage to occur. Limited space and time to maneuver may promote shoving and impacting the pallet. The irregular surfaces of dock plates may offer resistance to movement and increase shoving forces. The following observations can be made to help assess the required durability of the pallet.

- Size of dock area
- Traffic level in dock area
- Type of fork tips used (rotational shoving action best handled by rounded tips)
- Thickness of fork tips (tips are sharpened through floor abrasion)
- How often pallets are re-oriented
- Load amount and type of distribution
- Equipment clearances under pallet (sometimes pallet jacks must shove overloaded or inadequate pallets)
- Temperature of pallet
- Train push handling occurrence

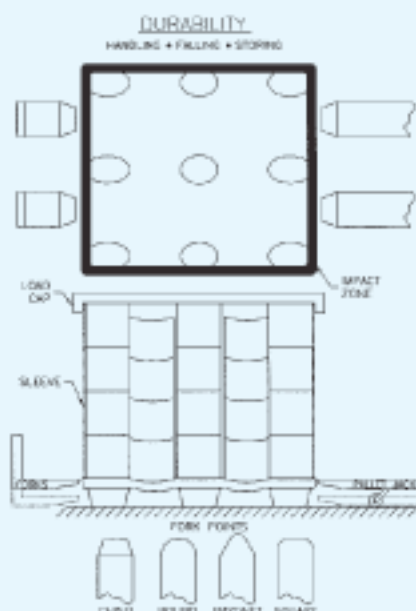

Pack Ratings

The pack rating indicates the ability of a container to support internal and external loads. The container can be a rigid wall, knock-down, or of sleeve-pack type. Typically, containers secure and protect a wide variety of contents from damage, (i.e.: Clothing, fluids, auto components, etc.). The content may be carefully arranged or random. Containers are used through-out the logistics industry, but the features and options vary with the markets in which they are used (i.e.: Food growers require ventilation features, while automotive requires dust protection.).

There are three areas of concern regarding physical performance of containers, While supporting loads and maintaining equipment clearances.

1. SIDE-WALL BOW — Containers become wedged into locations and are difficult to remove if the side-walls increase the foot-print size by bowing. The bow is caused by outward pressure from the content and varies with the type of load. Downward forces from stacked containers also contribute to the bow. The bow will sometimes increase due to transportation dynamics and temperature changes. A single laboratory test cannot reasonably predict sidewall bow, which is often unique to applications (i.e. heads of cabbage to automotive door knobs). Test values can create a good comparison from one container design to another, and indicate which may offer more resistance to bowing.

2. FLOOR CLEARANCE — Adequate floor clearance is important to assure access to pallet and fork trucks. Deformations are caused by the content and stacked units. The corners of a container sidewalls support the mass weight of stacked units being transferred. Typically, the most stressed area is the top edge down to the corner legs.

3. FORK ACCESS—

Deformations caused by stacked units reduce the opening fork truck access opening. Efforts to maximize a container's volume often minimizes floor and fork — failure to consider deformations caused by varying load conditions. Excessive deformations may cause damage to contents and prohibit fork entry.

Performance Recommendations

The bow in a sidewall should not increase a rated load's footprint by more than one inch on either side. Neither should it reduce the floor clearance to less than 3.25-inches (if designed for pallet trucks) nor the fork access to less than 2.5-inches within a 96-hour period (most deformations occur within 24-hours).

Test Methods

Sidewall Flex Test — Air pressure is increased within the container by use of an air bag while the cover is restrained. Sidewall bowing is measured at regular intervals.

Cover Strength — A concentrated load is applied to a container which is stacked upon another container. Forces are recorded at incremental deformations. Fork access opening is related to deformations.

Stack Strength — Two stacked containers are placed within a press instrument to measure force, displacement, and sidewall bowing. Floor clearance and fork access are also monitored.

Application Considerations

Containers are used to ship a wide range of products . The products can vary from tomato paste (heavy fluids) to boxed gifts (light semi-rigid). It is very difficult to predict deformations of a specific application using only laboratory tools .

- Temperature and humidity of container environment
- Load and the type of distribution
- Support conditions: Rack, stack, conveyor, etc.
- Available volume for sidewall bow
- Clearances inside loaded container
- Equipment access clearances
- Load bearing ability of content

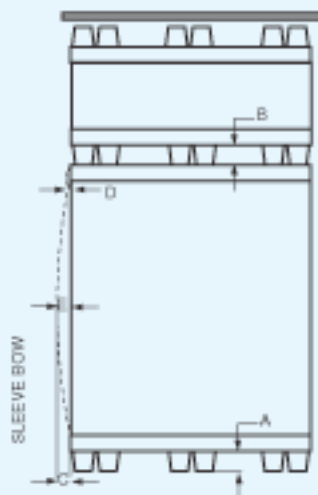

Life Cycle Rating

The total economic performance of a shipping pallet or container can only be determined by estimating its useful life. Typically, a life cycle test is defined when the sequence, type and frequency of pallet handling operation's moves goods from one point to another in a prescribed cycle.

There is no industry definition for a series of defined handling operations,

which make up a standard cycle.

A pallet handling operation usually relates to a pallet's interaction with equipment and loads. The definition per handling test protocols vary with user and industry. TriEnda's protocol rating is compiled from major industry studies.

Cost per trip

Plastic product designers can not opti-

mizes trip life without an accurate definition of dynamics for each handling and sequence of handling which define a trip (handling & sequence vary with markets).

The logistics industry will realize significant savings through plastic material handling products when an accurate universal definition of handling dynamics is available to designers.

Load Treatment Vs. Pallet Deflection

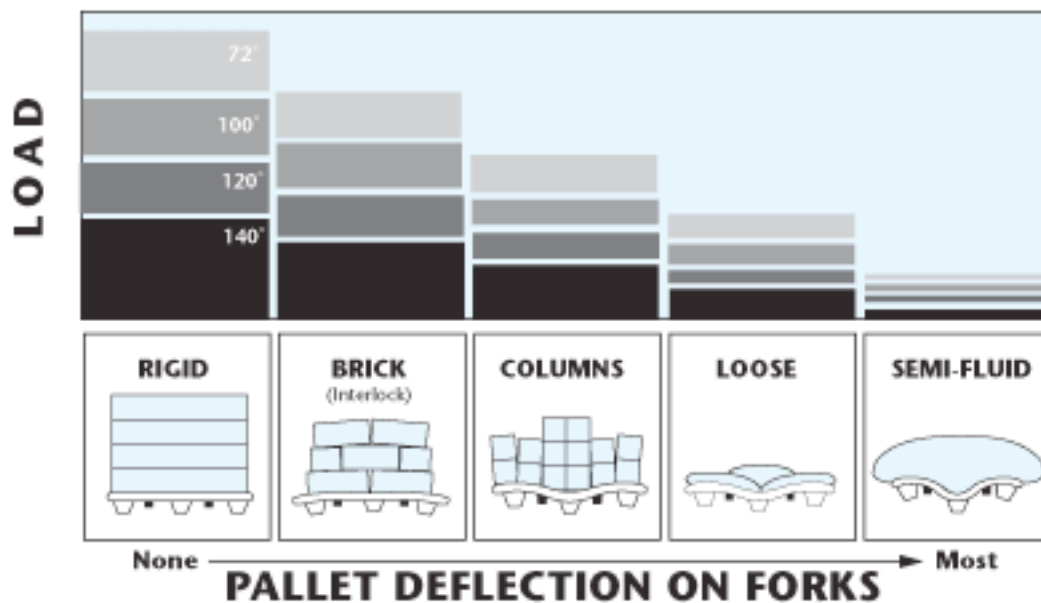

Fork load ratings are measured in a laboratory. And values are established by measuring pallet deflection. Semi-fluid loads have the most deflection and rigid loads have the least deflection.

Of the five load treatments illustrated, all are reliable and can be duplicated in a laboratory. Using laboratory equipment to measure pallet deflection on actual applications is not practical. This is due to the large number of variables introduced during testing. The allowable deflection also depends on the unique conditions a user subjects to a pallet. Some conditions and variables are:

- **Load construction:** Size, shade, weight, temperature, humidity, surface, material, density, and rigidity of container and content.
- **Transportation:** Mode, duration, climate, and floor conditions.
- **Load retention:** Width, thickness, tension, and type of banding or wrap.
- **User facility:** Type of equipment, maneuvering room, amount of traffic on facility floor, floor grades, and allowable operation speeds.
- **Temperature:** Elevated temperatures may reduce plastic stiffness. A truck or trailer's temperature may reach 140° F. At this temperature, a pallet's load capacity can be reduced by 40%. Compare this to a pallet's load capacity at 72° F. Sub-zero temperatures (i.e., freezers or northern winter climates), make materials like polypropylene — used in tote bins and container sidewalls — more prone to cracking under impact.

Each user must carefully consider the application requirements and accept final responsibility for a pallet's suitability according to its intended use.

SITE TESTING

Often a prospective buyer of plastic pallets will request a variety of samples to evaluate. The manufacturer's performance data may be unclear so comparison tests may need to be scheduled in order to select a pallet. Suggested procedures, which examine some of the important performance characteristics of plastic pallets are as follows.

Plastic Pallet Evaluation Procedure ^{1.}

The advantages of plastic pallets are rapidly being understood and accepted. The potential return on investment is often too great to be ignored. Because of this fact many new plastic pallet manufacturers are beginning production and most if not all, are willing to send samples for evaluation in order to gain sales.

This evaluation procedure has been designed to help develop an accurate assessment of different loaded plastic.

Three areas are assessed: stiffness, impact resistance, and general features.

First: Determine the type of pallet being tested.

Method of Manufacture: Thermoformed
Injection molded
Rotomolding
Blowmolding

Type of Plastic Used: High Density Polyethylene (HDPE)
HDPE with additives (mica, talc, etc.)
HDPE with foaming/expanding agents

NOTE:

The USPS study done by Michigan State University determined that Twin-Sheet Thermoformed Pallets made of HDPE have the best overall performance.

Note: Additives to enhance HDPE stiffness may make product more brittle

Weight: Compare weights.
The lighter pallet, with its recommended stiffness, is more desirable. Lighter weight pallets directly relates to increased fuel savings and fewer back injuries.

Second: Develop A Pallet Comparison Chart.

List features down one side.
Indicate the different pallets across the top.
Create a grid work and check the boxes appropriate to each vendor.

Decide which features are most important in your application and compare this to the chart.

2.

Its time to start the evaluation!

STIFFNESS

1. With the pallet on the floor, load the product in column or brick stacks, for a controlled test, we suggest using tightly boxed goods which have a foot print of 8' x 10'. This will provide a 5' x 5' pattern on a 40" x 48" pallet, with an inch overhang on the 48" side.
2. Etch marks on the top of the boxes II on both sides of the column space.
3. Center the pallet truck under the pallet in the 40" direction (make sure the forks are under completely), lift off the floor. This positioning must be exactly the same on all pallets tested.
Remember: This position must be exactly the same on all pallets tested.
4. Measure the increased space between the marks. Allow the column to lean outward, now record the indicated spread.

CONCLUSION: Compare all pallets tested. The pallet which indicates the least spacing (less column lean) is the most rigid.

IMPACT RESISTANCE

Hold the pallet over the edge of the loading dock with one corner down.
Drop on the pavement.
Repeat the test on all four corners (some pallets may dent, others may break apart)
Record the results
(ND-No Damage, D-Damaged, B-Broken)

NOTE: Some dents may self-heal in a few hours.

CONCLUSION: The pallet which exhibits the least damage has greater impact resistance.

If it can be arranged, photographs of test results should be taken for documentation.

3.

Load pallet with boxes of uniform size.

With pallet on the floor, place marks on boxes 1" in from the edge.

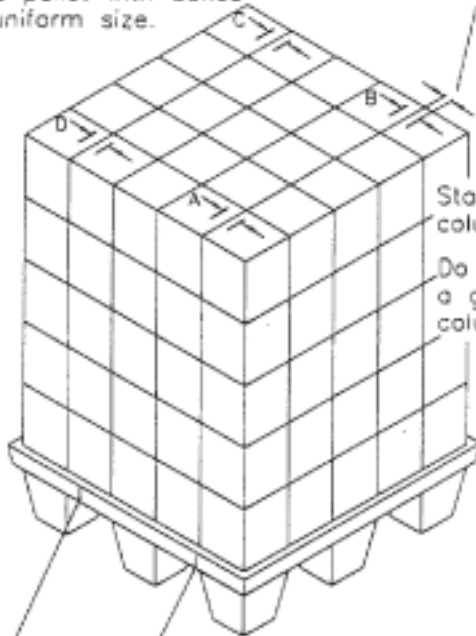

Stack boxes in columns.

Do not leave a gap between columns.

Position forks under marks on pallet.

Total load on pallet should represent total average load to be used.

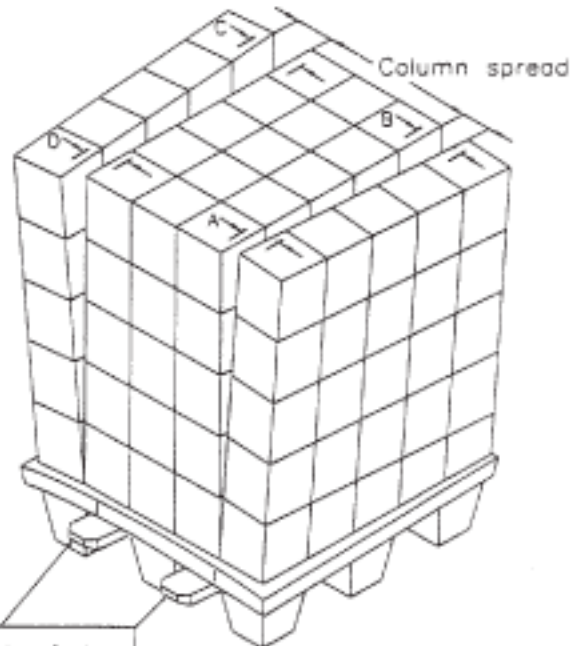

Pallet supported by forks.

PALLET MFR.	PALLET WEIGHT	PALLET DECK DEFLECTION**				AVERAGE OF ALL 4 COLUMNS	DROP TEST - DENT CRACKED BROKEN	APPROX. TEMP. OF PALLET
		A	B	C	D			

**Measure change in column spread, 2 minutes after lifting.

Information in this document is subject to change without notice and does not represent a commitment on the part of TriEnda. No part of this document may be reproduced or transmitted in any form or by any means, electronic or mechanical, including photocopying, recording, or any information retrieval and storage system, for any purpose without the written permission of TriEnda®.

Comments, criticisms and suggestions are invited, and should be forwarded to TriEnda®.

Please Note: Although the information in this volume has been obtained from sources believed to be reliable, no warranty, expressed or implied, can be made as to its completeness or accuracy. Design, processing, methods, equipment, environment and other variables effect actual part and mechanical performance. Inasmuch as manufacturers, suppliers and TriEnda have no control over those variables or the use to which others may put the material and, therefore, cannot assume responsibility for loss or damages suffered through reliance on any information contained in this volume. No warranty is given or implied as to application and to whether there is an infringement of patents is the sole responsibility of the user. The information provided should assist in material selection and not serve as a substitute for careful testing of Material Handling Products within typical operating environments before beginning commercial production or procurement.

Manufactured in the United States of America



N7660 Industrial Road • Portage, Wisconsin 53901-9154
Tele: 608.742.5303 • 800.356.8150 • Fax: 608.742.9164 • www.triendacom