



Material Handling Solutions and Custom Products

DC1 4048NLT



FEATURES

- ▲ Made from HDPE – Environmentally friendly and 100% recyclable
- ▲ Fully nestable to conserve space – Lowers return cost
- ▲ Lightweight for better Ergonomics – Worker friendly
- ▲ 4 way entry for forklift and pallet jack – Provides quick and easy handling
- ▲ Patented TriMax™ Design – Increases deck stiffness and durability
- ▲ Easy to clean
- ▲ Oval leg design – Minimizes damage caused by fork-tines
- ▲ Legs without drain holes

OPTIONS

- ▲ Custom color(s)
- ▲ Custom stripe(s) – Only in 48" direction
- ▲ Leg drain holes available
- ▲ Logo plate placement
- ▲ Pocket recesses for label placement
- ▲ Anti-skid material – Significantly reduces product damage



DC1 4048NLT Specifics

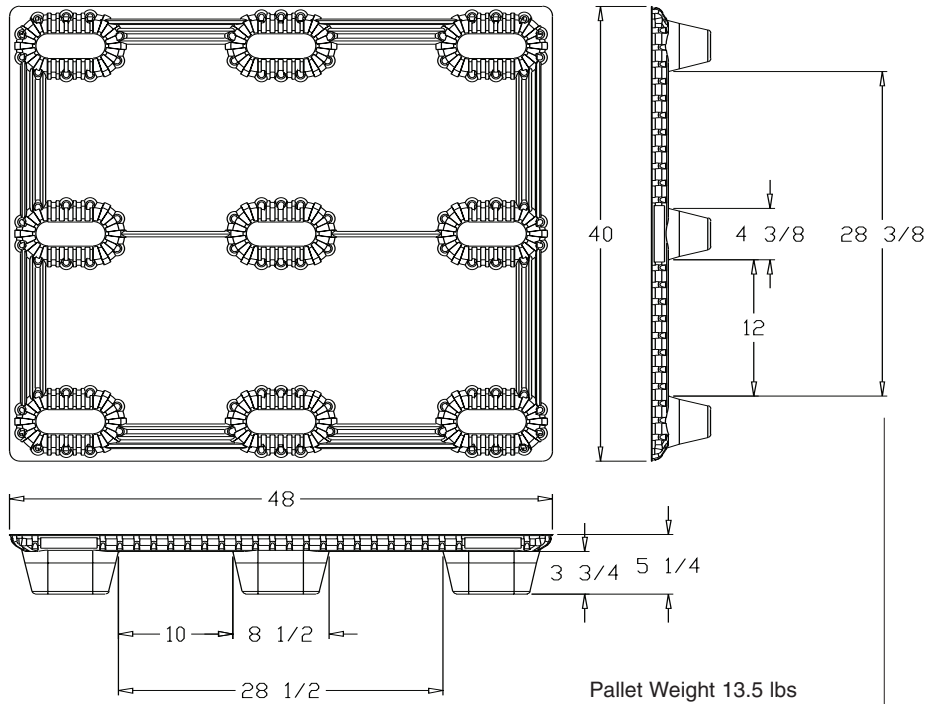

Oval 9 leg Design



In-transit Stability

Pallet Underside



Fully Nestable



Load Rating

	English	Metric
Floor Load Rating	3,000 lbs	1,364 kg
Fork Load Rating	1,500 lbs	.682 kg

Packaging

Stack Height	100"
# Pallets per Stack	50
Qty Pallets per 48 ft trailer	1,680
Qty Pallets per 53 ft trailer	1,800
Qty Pallets per 20 ft container	(540 min) 600
Qty Pallets per 40 ft container	(1,200 min) 1,320
Qty Pallets per 40 ft HC	1,160
Qty Pallets per 45 ft container	1,166



TriEnda publishes standard guidelines for its products, based on its testing standards, and, as such, these guidelines do not constitute any warranty related to each customer's individual application. The material handling industry has not standardized on test methodology and rating criteria for each individual product. All TriEnda products are sold with the understanding that the customer will validate for themselves the suitability of the product for their specific application. As each product application is unique, the customer assumes all risks associated with the determination and actual use of the pallet.