

DC4V 4048TP



FEATURES

- ▲ Made from HDPE – Environmentally friendly and 100% recyclable
- ▲ Fully nestable to conserve space – Lowers return cost
- ▲ Lightweight for better Ergonomics – Worker friendly
- ▲ 4 way entry for forklift and pallet jack – Provides quick and easy handling
- ▲ Patented TriMax™ Design – Increases deck stiffness and durability
- ▲ Drain Holes
- ▲ Easy to clean
- ▲ Oval leg design – Minimizes damage caused by fork-tines

OPTIONS

- ▲ Custom color(s)
- ▲ Custom stripe(s) – Only in 48" direction
- ▲ Legs drain holes available
- ▲ Custom logos
- ▲ Pocket recesses for label placement
- ▲ Ever-Lok®2 locations for package/unit security, also eliminates the need for stretch wrapping
- ▲ Sleeve groove channel for sleeve option
- ▲ Cargo Lip
- ▲ Anti-skid material – Significantly reduces product damage



DC4V 4048TP Specifics

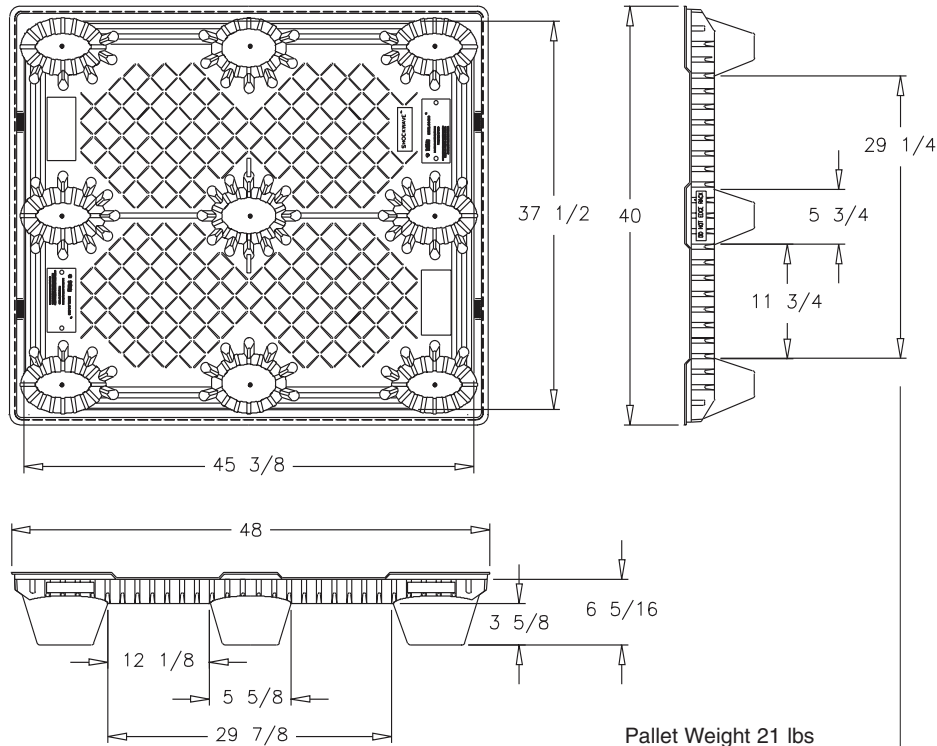

Oval 9 leg Design



In-transit Stability



Pallet Underside



Big Pak Sleeve Options

Fiberboard Z-fold design



Twin-sheet Thermoformed



Fluted Plastic



Load Rating

	English	Metric
Floor Load Rating	6,500 lbs	2,955 kg
Fork Load Rating	2,500 lbs	1,136 kg

Packaging

Stack Height	100"
# Pallets per Stack (100")	36
Qty Pallets per 48 ft trailer	1,008
Qty Pallets per 53 ft trailer	1,080
Qty Pallets per 20 ft container	324
Qty Pallets per 40 ft container	720
Qty Pallets per 40 ft HC	760
Qty Pallets per 45 ft HC	748

Ever-lok®2



TriEnda publishes standard guidelines for its products, based on its testing standards, and, as such, these guidelines do not constitute any warranty related to each customer's individual application. The material handling industry has not standardized on test methodology and rating criteria for each individual product. All TriEnda products are sold with the understanding that the customer will validate for themselves the suitability of the product for their specific application. As each product application is unique, the customer assumes all risks associated with the determination and actual use of the pallet.