



Material Handling Solutions and Custom Products

HP4048TP One-Way/Export



FEATURES

- ▲ Made from HDPE – Environmentally friendly and 100% recyclable
- ▲ Lightweight for better Ergonomics – Worker friendly
- ▲ Oval Leg Design – Minimizes damage caused by fork tines
- ▲ 4 way entry for forklift and pallet jack – Provides quick and easy handling
- ▲ Patented TriMax™ Design – Increases deck stiffness and durability
- ▲ Oval leg design – Minimizes damage caused by fork-tines
- ▲ One white stripe
- ▲ Legs without drain holes

OPTIONS

- ▲ Custom color(s)
- ▲ Custom stripe(s) – Only in 48" direction
- ▲ Custom logos
- ▲ Leg drain holes



HP4048TP One-Way/Export Specifics

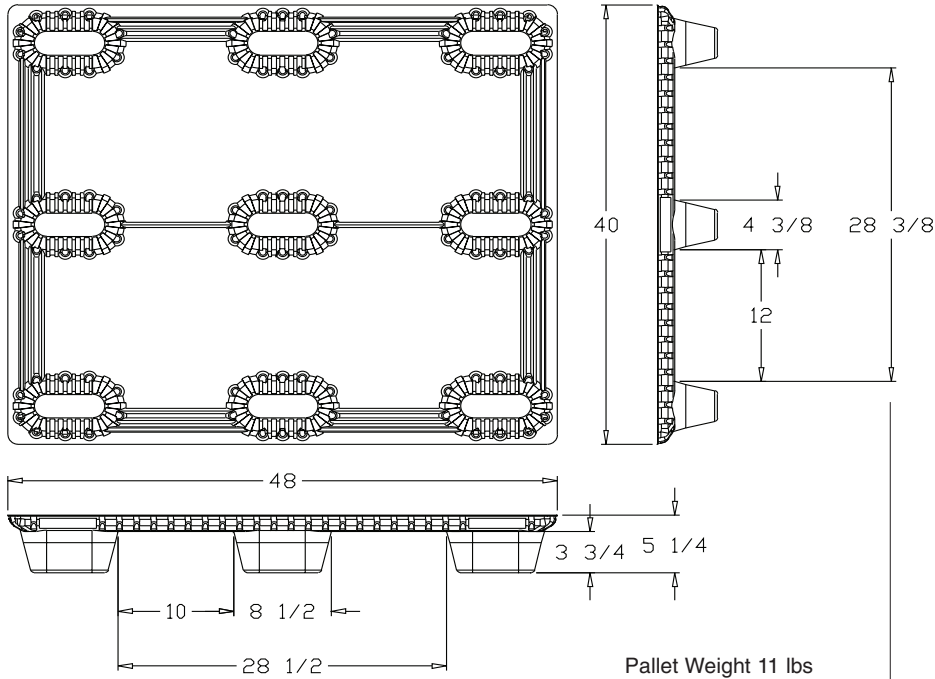

Oval 9 leg Design



In-transit Stability

Pallet Underside



Fully Nestable



Rating

	English	Metric
Floor Load Rating	2,000 lbs	909 kg
Fork Load Rating	1,000 lbs	454 kg

Packaging

Stack Height	100"
# Pallets per Stack	60
Qty Pallets per 48 ft trailer	1,680
Qty Pallets per 53 ft trailer	1,800
Qty Pallets per 20 ft container	540
Qty Pallets per 40 ft container	1,200
Qty Pallets per 40 ft HC	1,160
Qty Pallets per 45 ft container	1,166



TriEnda publishes standard guidelines for its products, based on its testing standards, and, as such, these guidelines do not constitute any warranty related to each customer's individual application. The material handling industry has not standardized on test methodology and rating criteria for each individual product. All TriEnda products are sold with the understanding that the customer will validate for themselves the suitability of the product for their specific application. As each product application is unique, the customer assumes all risks associated with the determination and actual use of the pallet.