

International Pallet

1200x800 mm

Thermoformed
HDPE Twin Sheet
Construction

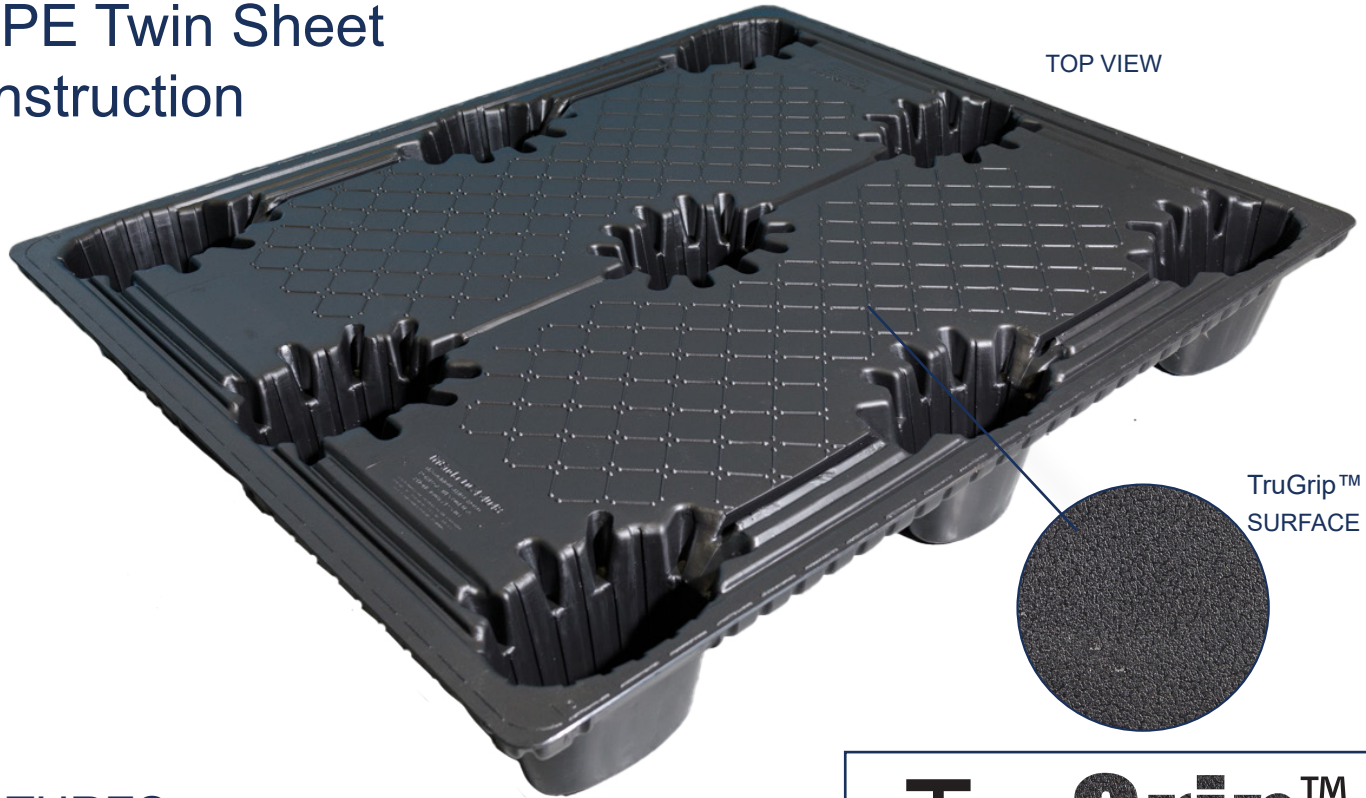

TOP VIEW

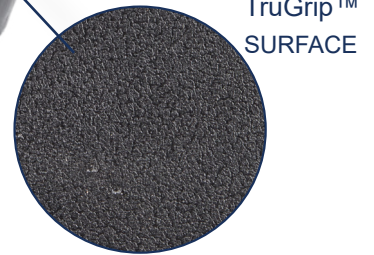

TruGrip™
SURFACE

FEATURES

- Impact absorbing TriMax™ design for added stiffness and durability
- Lightweight for better ergonomics
- Oval leg design for minimized damage
- Nestable 3:1

OPTIONS

- RFID
- TruGrip™ highest coefficient of friction
- Custom labels
- Drain holes

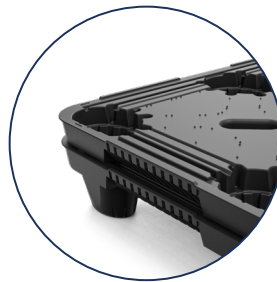

Nestable Design

TruGrip™

An anti-skid surface like no other

Introducing TruGrip™ offering the highest COF available on the market using a proprietary rubber-like material. Prevents slippage of boxes, on fork tines and on floors.

SPECIFICATIONS

PRODUCT	DESCRIPTION	DIMENSIONS			WEIGHT AND COLOR	RATINGS		QTY PER STACK		QTY 53' TRUCK	QTY 40' SC
		L	W	H		DYNAMIC	STATIC	PALLETS PER STACK	PALLETS PER STACK SC		
International 800x 1200mm	Universal Twin Sheet Pallet	47.24" 1200 mm	31.5" 800 mm	5.5" 140 mm	15 lbs 6.8 kg Black	992.08 lbs 450 kg	4850.17 lbs 2,200 kg	40	40	2,250	1,176

INTERNATIONAL PALLET SPECIFICATIONS

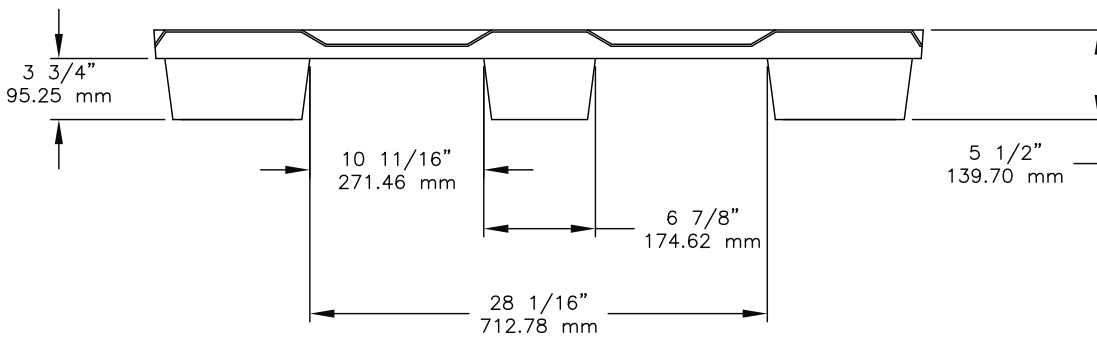
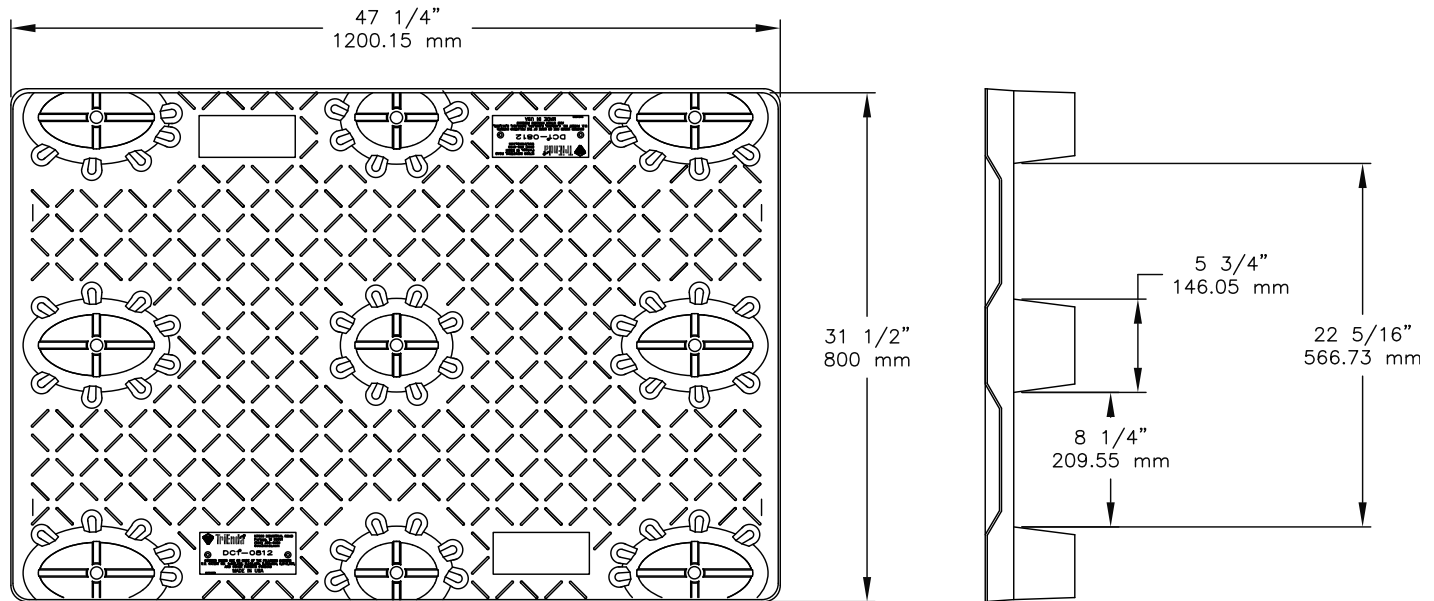

Pallet Advantages

Environmentally Friendly
 ISPM 15 Exempt
 Long Service Life



Easy Clean



Sanitary



Weather Resistant



Impact Resistant



4-Way Forklift & Forkjack Entry



Recycle

TriEnda publishes standard guidelines for its products, based on its testing standards, and, as such, these guidelines do not constitute any warranty related to each customer's individual application. The material handling industry has not standardized on test methodology and rating criteria for each individual product. All TriEnda products are sold with the understanding that the customer will validate for themselves the suitability of the product for their specific application. As each product application is unique, the customer assumes all risks associated with the determination and actual use of the pallet.

