

GS 1100x1200 Pallet

Top View

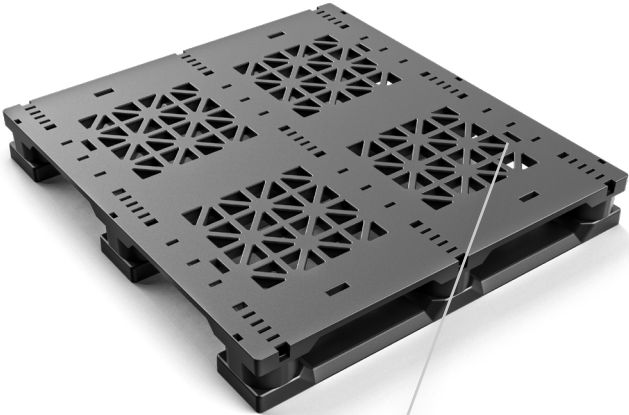

FEATURES

- High-pressure injection molded design using HDPE for optimal performance and durability
- Full picture frame runner system for enhanced versatility and racking capability
- Grommets on top and bottom decks to mitigate slippage
- 8 grommets in top deck, 9 grommets in bottom deck
- Environmentally friendly and 100% recyclable
- No splinters, broken wood, or nails

OPTIONS

- Different configurations and quantities (0 or 3) of fiberglass rods to accommodate most racking requirements
- Alternative material blends and colors for custom applications
- Fully decked bottom or runners in either direction
- Ink stamping for company logos and branding

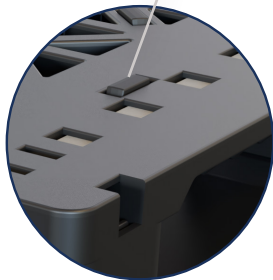

Grommets

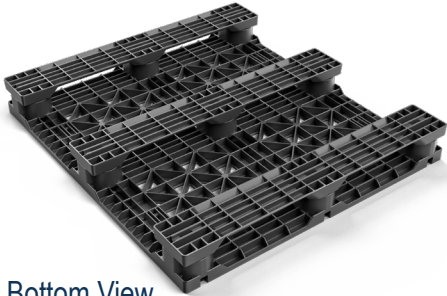

Bottom View



40" Side View

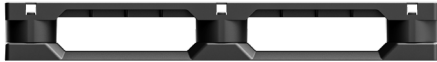

48" Side View



Reinforcement Rods and Ink Stamping

SPECIFICATIONS

PRODUCT	DESCRIPTION	DIMENSIONS			WEIGHT AND COLOR	RATINGS			QTY 53' TLD	QTY 40' SC
		L	W	H		DYNAMIC	STATIC	RACKING		
GS.11001200.6R0	0 rods	47.25" 1,200 mm	43.31" 1,100 mm	5.75" 146.05 mm	62 lbs 28.12 kg Black	5,000 lbs 2,268 kg	30,000 lbs 13,608 kg	1,500 lbs 680 kg	504	304
GS.11001200.6R3	3 Rods	47.25" 1,200 mm	43.31" 1,100 mm	5.75" 146.05 mm	67 lbs 30.39 kg Black	5,000 lbs 2,268 kg	30,000 lbs 13,608 kg	2,800 lbs 1,270 kg	504	304

Performance characteristics vary with applications. To optimize nominal specifications, loads must be evenly distributed to reach capacity. Load construction, support conditions, transportation, load retention, user facility and temperature are factors that affect pallet capacity.

GS 1100x1200 Pallet

SPECIFICATIONS

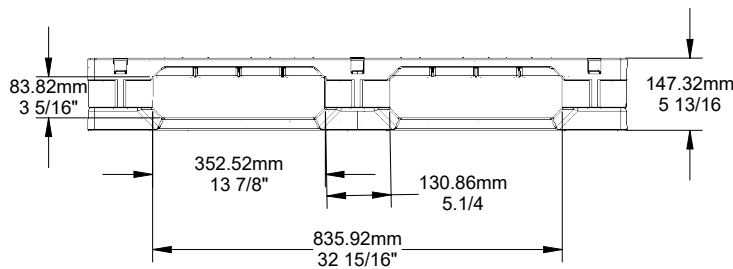
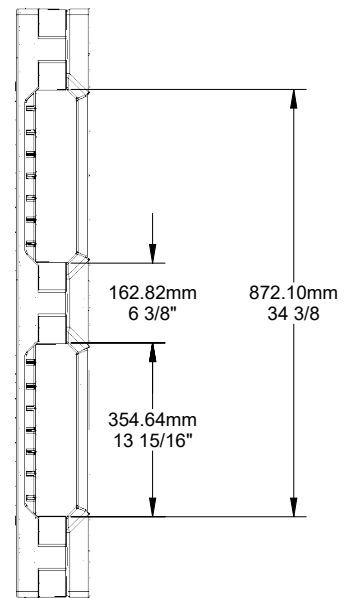
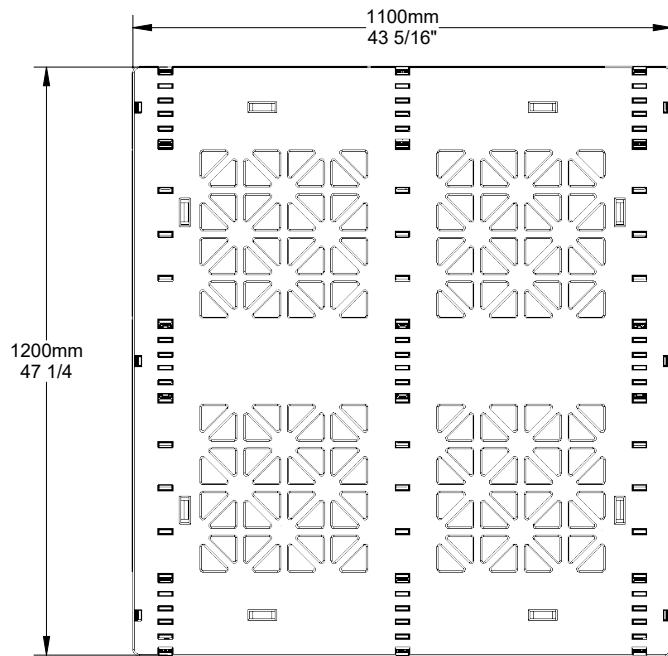

Pallet Advantages

Environmentally Friendly
ISPM 15 Exempt
Long Service Life



Easy Clean



Sanitary



Weather Resistant



Impact Resistant



4-Way Forklift & Forkjack Entry



Recycle

TriEnda publishes standard guidelines for its products, based on its testing standards, and, as such, these guidelines do not constitute any warranty related to each customer's individual application. The material handling industry has not standardized on test methodology and rating criteria for each individual product. All TriEnda products are sold with the understanding that the customer will validate for themselves the suitability of the product for their specific application. As each product application is unique, the customer assumes all risks associated with the determination and actual use of the pallet.

