

Tough Pallet™ 40x48

Heavy Duty Thermoformed HDPE Construction FEATURES

- Sanitary--no hollow areas
- Molded in no-rust steel bars for strength & rigidity
- Thick nominal walls of 0.35"
- Provides minimal dynamic and rack deflection
- Unique design allows for racking pallet in 40" direction
- Lightweight and nestable--minimizing storage space and reducing shipping costs
- Standard two 4" yellow stripes in 48" direction



OPTIONS

- Drain holes
- Wide range of stripe colors
- One or multiple stripes in 48" direction
- FDA materials available with virgin resin



Secure
Combo Hold



Racking
Feature



Fully
Nestable

SPECIFICATIONS

PRODUCT	DIMENSIONS			WEIGHT AND COLOR	RATINGS			STACK HEIGHT	QTY PER STACK		QTY 53' TLD	QTY 40' SC	QTY 40' HC
	L	W	H		STATIC (UP TO)	DYNAMIC (UP TO)	UNSUPPORTED RACK		STD.	HC			
Reinforced Tough Pallet	48" 1,219.2 mm	40" 1,016 mm	7.75" 196.9 mm	35 lbs 15.88 kg Black	25,000 lbs 11,340 kg	4,000 lbs 1,814 kg	2,100 lbs 952.5kg	100" 2,540 mm	25	26	750	500	546
Tough Pallet™	48" 1,219.2 mm	40" 1,016 mm	7.75" 196.9 mm	28 lbs 12.70 kg Black	20,000 lbs 9,072 kg	3,000 lbs 1,361 kg	1,500 lbs 680.39 kg	100" 2,540 mm	25	26	750	500	546

SPECIFICATIONS

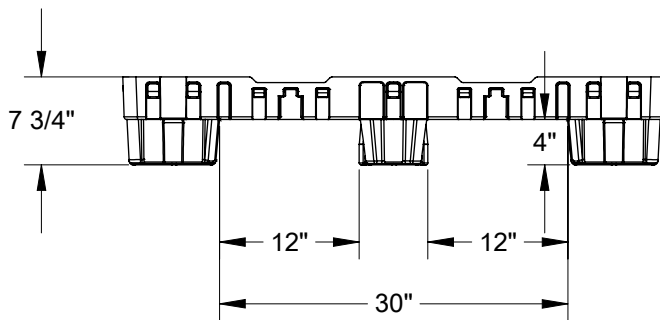
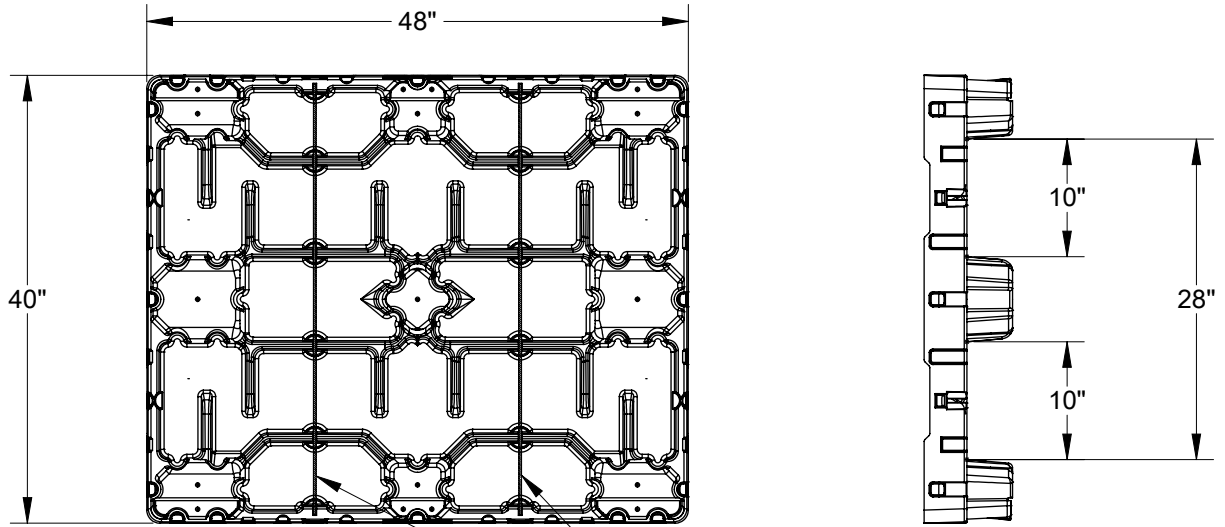

Note: Dimensions are reference only

Pallet Advantages

Environmentally Friendly
 ISPM 15 Exempt
 Long Service Life



TriEnda publishes standard guidelines for its products, based on its testing standards, and, as such, these guidelines do not constitute any warranty related to each customer's individual application. The material handling industry has not standardized on test methodology and rating criteria for each individual product. All TriEnda products are sold with the understanding that the customer will validate for themselves the suitability of the product for their specific application. As each product application is unique, the customer assumes all risks associated with the determination and actual use of the pallet.

