

**NEW!**

# One-Way Pallet

40x48

In- Stock  
Thermoformed  
HDPE  
Twin Sheet  
Construction

Top view



Bottom view



## FEATURES

- Impact Absorbing TriMax™ design for added stiffness and durability
- Impact resistant
- Lightweight for better ergonomics
- Oval leg design minimizes damage caused by fork-tines

## OPTIONS

- Custom logos and/or labels
- Handholds



Oval Legs

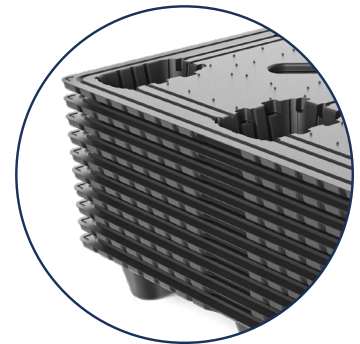

Nestable Pallet Design

## SPECIFICATIONS

PRODUCT	DESCRIPTION	DIMENSIONS			WEIGHT AND COLOR	RATINGS		STACK HEIGHT	QTY PER STACK		QTY 53' TLD	QTY 40' SC	QTY 40' HC
		L	W	H		DYNAMIC (UP TO)	STATIC (UP TO)		STD.	HC			
DC0 40x48	Twin Sheet One-Way Pallet	48" 1,219.2 mm	40" 1,016 mm	5.25" 133.4 mm	11.5 lbs 5.2 kg Black	2,200 lbs 998 kg	9,000 lbs 4,082 kg	100" 2,540 mm	60	68	1,920 pallets	1,200/ 20 Skids	1,360/ 20 Skids

# DC0 4048

## SPECIFICATIONS

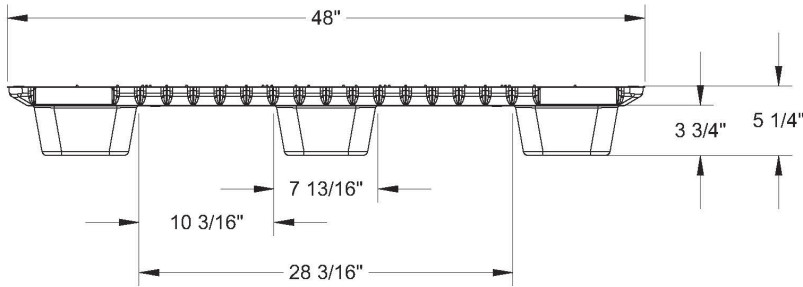
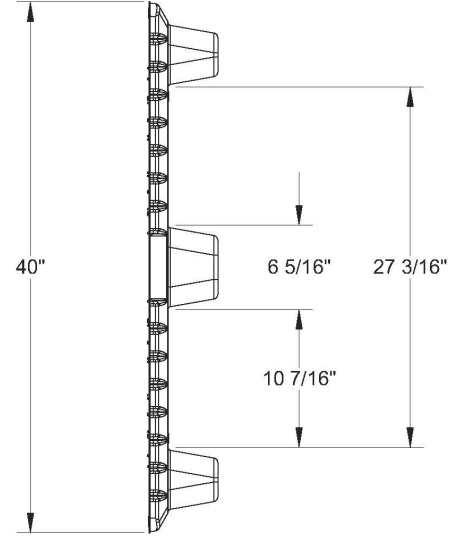
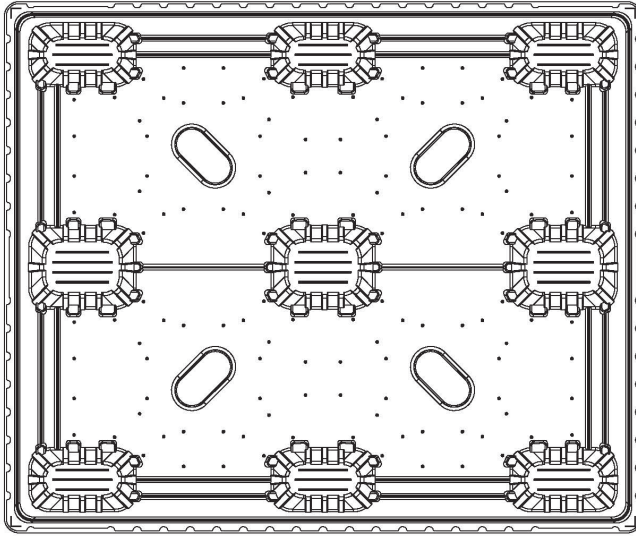

### Pallet Advantages

Environmentally Friendly  
ISPM 15 Exempt  
Long Service Life



Easy  
Clean



Sanitary



Weather  
Resistant



Impact  
Resistant



4-Way Forklift  
& Forklift  
Entry



Recycle

TriEnda publishes standard guidelines for its products, based on its testing standards, and, as such, these guidelines do not constitute any warranty related to each customer's individual application. The material handling industry has not standardized on test methodology and rating criteria for each individual product. All TriEnda products are sold with the understanding that the customer will validate for themselves the suitability of the product for their specific application. As each product application is unique, the customer assumes all risks associated with the determination and actual use of the pallet.



Pallet  
Buy Back  
Program

