

Economy Pallet

40x48 NLT

Thermoformed HDPE
Twin Sheet Construction

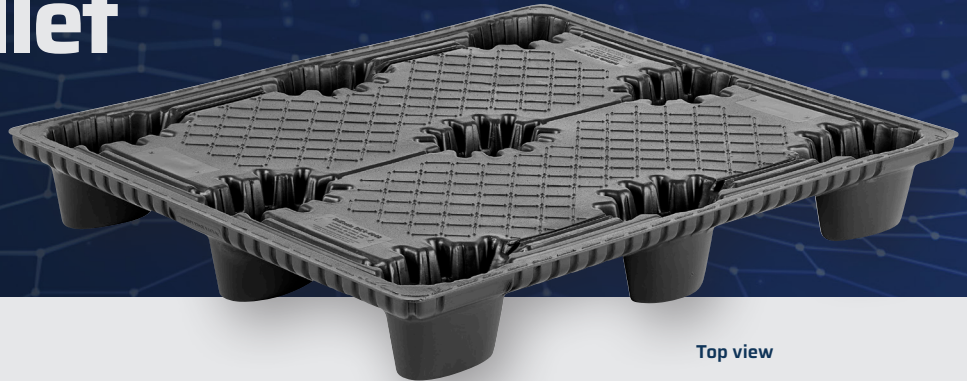

Top view

01 / Details

FEATURES

- Impact absorbing TriMax™ design for added stiffness and durability
- Impact resistant
- Lightweight for better ergonomics
- Oval leg design minimizes damage caused by fork tines



Bottom view

OPTIONS

- TruGrip™ highest coefficient of friction
- Stripe identification
- Grommets
- Custom logos and/or labels
- RFID
- Coditherm
- Drain holes



Oval Legs



Nestable Pallet Design

02 / Specifications

PRODUCT	DESCRIPTION	DIMENSIONS			WEIGHT	COLOR	RATINGS		STACK HEIGHT	QTY PER STACK		QTY 53' TLD	QTY 40' SC	QTY 40' HC
		L	W	H			DYNAMIC (UP TO)	STATIC (UP TO)		STD.	HC			
DC1 4048NLT	Twin Sheet Pallet	48" 1,219 mm	40" 1,016 mm	5.25" 133 mm	11.5 lbs 6 kg	Black	2,500 lbs 1,134 kg	10,000 lbs 4,536 kg	100" 2,743 mm	60	62	1,800/ 30 Skids	1,200/ 20 Skids	1,240/ 20 Skids

Performance characteristics vary with applications. To optimize nominal specifications, loads must be evenly distributed to reach capacity. Load construction, support conditions, transportation, load retention, user facility and temperature are factors that affect pallet capacity.

Economy Pallet 40x48 NLT

SPECIFICATIONS

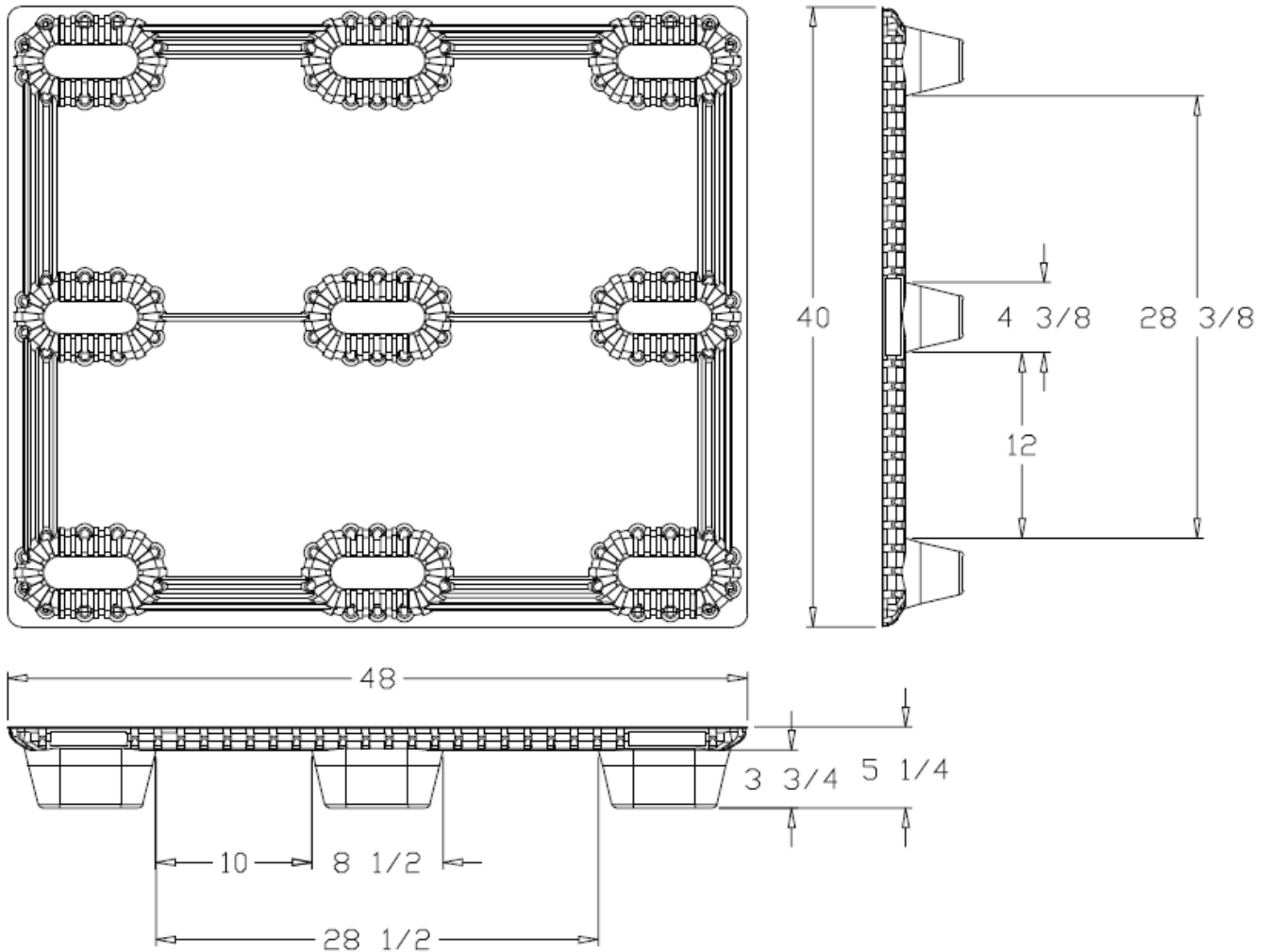

PALLET ADVANTAGES

- Environmentally Friendly
- ISPM 15 Exempt
- Long Service Life



Easy
Clean



Sanitary



Weather
Resistant



Impact
Resistant



4-Way
Forklift/jack
Entry



Recycle

TriEnda publishes standard guidelines for its products, based on its testing standards, and, as such, these guidelines do not constitute any warranty related to each customer's individual application. The material handling industry has not standardized on test methodology and rating criteria for each individual product. All TriEnda products are sold with the understanding that the customer will validate for themselves the suitability of the product for their specific application. As each product application is unique, the customer assumes all risks associated with the determination and actual use of the pallet.



CONTACT US

N7660 Industrial Road Portage, WI 53901
www.triend.com | sales@triend.com
1-800-356-8150

**PALLET
BUYBACK
PROGRAM**

