

Delivery Cart

40x30

Thermoformed HDPE
Twin Sheet Construction

01 / Details

FEATURES

- Perimeter lip for product security
- Comfort-height handle
- Impact-resistant
- Sanitary and easy to clean
- Lightweight for better ergonomics
- Ergonomic Handholds
- Premium locking wheels for easy maneuvering
- 30" deck fits narrow spaces and delivery doors

OPTIONS

- TruGrip™ highest coefficient of friction
- FDA materials available with virgin resin
- Drain holes



TruGrip™
An anti-skid surface like no other

Introducing TruGrip™ offering the highest COF available on the market using a proprietary rubber-like material. Prevents slippage of boxes on fork tines and on floors.



Premium locking wheels

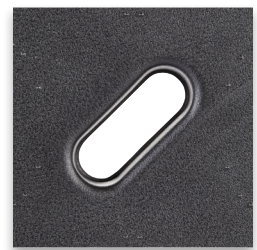

Ergonomic Hand Holes

02 / Specifications

PRODUCT	DIMENSIONS			WEIGHT	DYNAMIC RATING	COLOR	STACK HEIGHT	QUANTITY					
	L	W	H					53' TLD		40' SC		40' HC	
								PER STACK	TOTAL	PER STACK	TOTAL	PER STACK	TOTAL
Delivery Cart	42" 1,067 mm	30" 762 mm	10" 254 mm	68 lbs 31 kg	2,000 lbs 907 kg	Black	105" 2,667 mm	12	528	15	300	17	340

Performance characteristics vary with applications. To optimize nominal specifications, loads must be evenly distributed to reach capacity. Load construction, support conditions, transportation, load retention, user facility and temperature are factors that affect pallet capacity.

Delivery Cart

SPECIFICATIONS

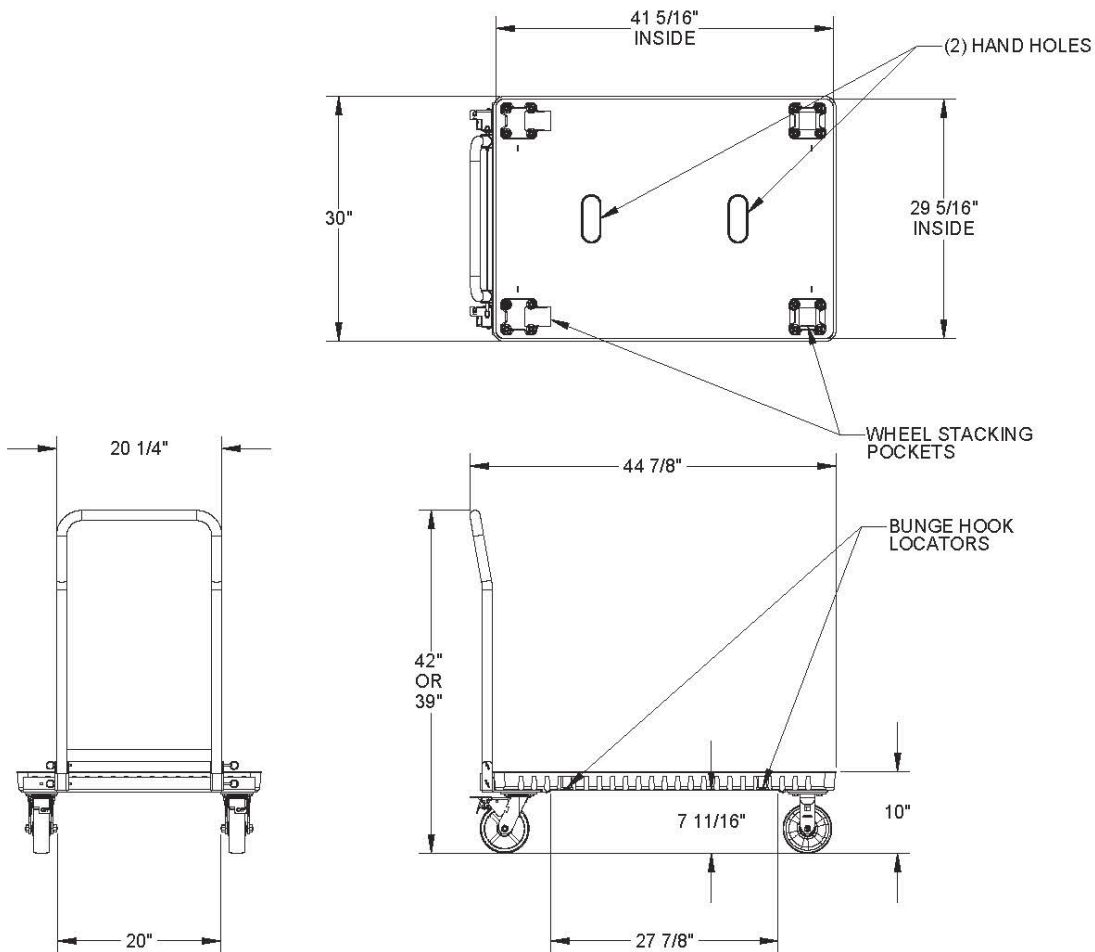

PALLET ADVANTAGES

- Environmentally Friendly
- ISPM 15 Exempt
- Long Service Life



Easy Clean



Sanitary



Weather Resistant



Impact Resistant



4-Way Forklift/jack Entry



Recycle

TriEnda publishes standard guidelines for its products, based on its testing standards, and, as such, these guidelines do not constitute any warranty related to each customer's individual application. The material handling industry has not standardized on test methodology and rating criteria for each individual product. All TriEnda products are sold with the understanding that the customer will validate for themselves the suitability of the product for their specific application. As each product application is unique, the customer assumes all risks associated with the determination and actual use of the pallet.

