

DAIRY TRAYS AND PALLETS

Compatible with Conveyor and Automation Systems

01 / Details

TriEnda's thermoformed Dairy Product trays redefine packaging excellence.

Fully customizable to your specifications, these trays epitomize durability, ensuring robust protection for your dairy products.

Single sheet or twin sheet construction, small or large format pallets - our experienced Engineering team is available to design a 100% recyclable solution for your application.

Choose TriEnda for trays that combine precision customization, unmatched durability, and an eco-friendly approach, setting a new standard in dairy packaging.



5x6 Tray (with and without product)
37x32 Rackable Pallet
5 levels high

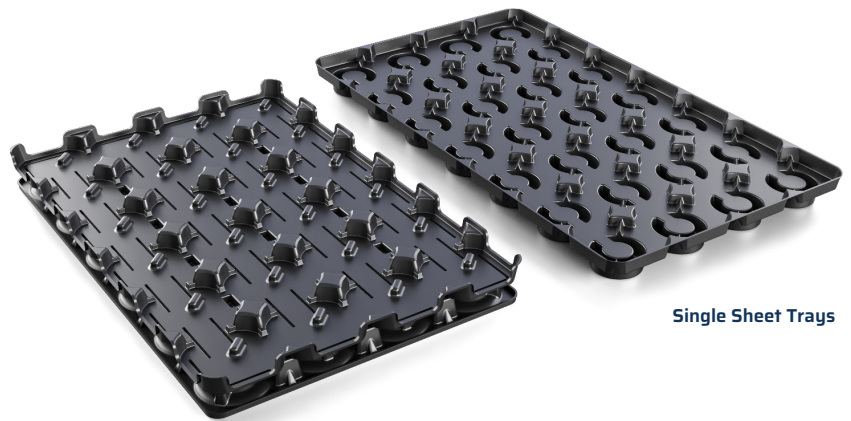

Single Sheet Trays

Twin Sheet Trays



**CUSTOM DESIGNED
TO FIT YOUR PRODUCT**



**MAXIMIZE STORAGE AND
RETAIL MERCHANDISING**

02 / Specifications

- Durable storage, display, and shipping option
- HDPE Material for cold climate applications
- Single and Twin Sheet Available
- Customizable to any size plastic carton
- Hygienic
- Returnable Reusable Recyclable

DAIRY TRAYS

AND PALLETS

03 / Sample Drawing

Dairy Tray and Pallet SAMPLE DRAWING

- Tray on right shown with 37x32 pallet
- Single or Twin Sheet Thermoformed Tray
- Cavities can be customized to fit any dairy product size
- Tray size can vary depending on pallet dimensions
- Many pallet sizes already available as well as custom solutions to fit specific needs

Common pallet sizes available:

32" x 37"	48" x 40"
37" x 37"	48" x 48"
45" x 45"	56" x 44"
45" x 48"	1100mm x 1200mm

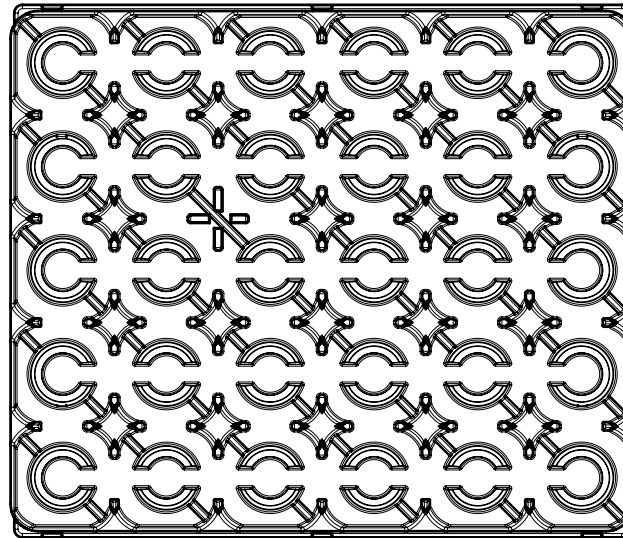

* Concept Drawing Shown

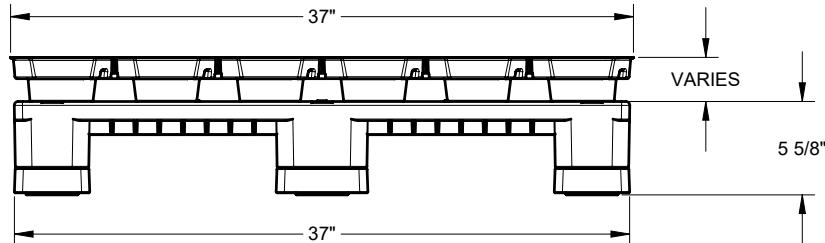
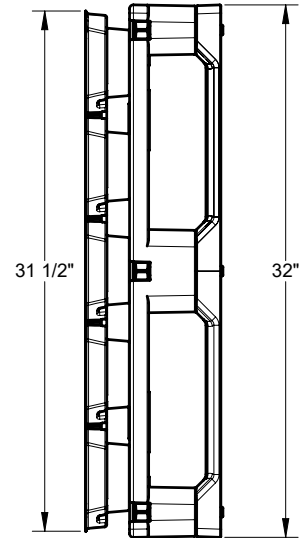

DAIRY PRODUCT TRAY ADVANTAGES

- Environmentally Friendly
- ISPM 15 Exempt
- Long Service Life
- 100% Recyclable & Reusable



Easy
Clean



Sanitary



Weather
Resistant



Impact
Resistant



Recyclable

TriEnda publishes standard guidelines for its products, based on its testing standards, and, as such, these guidelines do not constitute any warranty related to each customer's individual application. The material handling industry has not standardized on test methodology and rating criteria for each individual product. All TriEnda products are sold with the understanding that the customer will validate for themselves the suitability of the product for their specific application. As each product application is unique, the customer assumes all risks associated with the determination and actual use of the pallet.

