

Industrial Pallet*

40x48 OR 42x48

Thermoformed HDPE
Twin Sheet Construction

*formerly known as the DC4, DC4V/DC4V HP Pallets

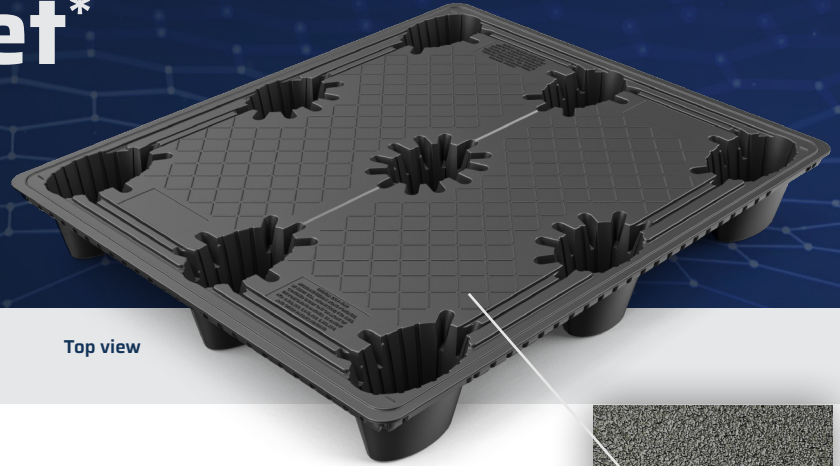

Top view

01 / Details

FEATURES

- Impact Absorbing TriMax™ design for added stiffness and durability
- Impact resistant
- Lightweight for better ergonomics
- Oval leg design minimizes damage caused by fork-tines

OPTIONS

- TruGrip™ highest coefficient of friction
- Stripe identification
- Grommets
- Custom logos and/or labels
- Drain holes
- DC4V with lipped edges (see below- 40x48 dimensions)
- DC4V nests with competitor models

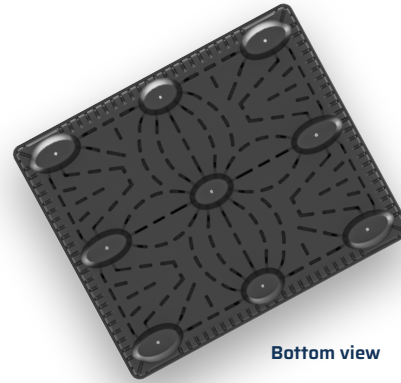

Bottom view



TruGrip™

An anti-skid surface like no other

Introducing TruGrip™ offering the highest COF available on the market using a proprietary rubber-like material. Prevents slippage of boxes on fork tines and on floors.



DC4V Lipped Edges



Oval Legs

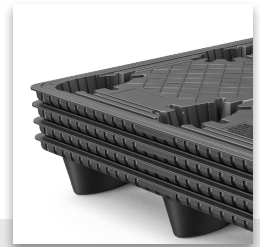

Nestable Design

02 / Specifications

PRODUCT	DESCRIPTION	DIMENSIONS			WEIGHT	COLOR	RATINGS		STACK HEIGHT	QTY PER STACK		QTY 53' TLD	QTY 40' SC	QTY 40' HC
		L	W	H			DYNAMIC	STATIC		STD	HC			
DC4 40x48	Twin Sheet Industrial Pallet	48" 1,219 mm	40" 1,016 mm	6.5" 165 mm	21 lbs 9.5 kg	Black	2,500 lbs 1,136 kg	6,500 lbs 2,955 kg	100" 2,540 mm	36	39	1,200/ 30 Skids	720/ 20 Skids	780/ 20 Skids
DC4 42x48	Twin Sheet Industrial Pallet	48" 1,219 mm	42" 1,067 mm	6.5" 165 mm	22 lbs 9.98 kg	Black	2,500 lbs 1,136 kg	6,500 lbs 2,955 kg	100" 2,540 mm	40	43	1,200/ 30 Skids	800/ 20 Skids	860/ 20 Skids
DC4V 40x48	Twin Sheet Industrial Pallet Lipped Edge	48" 1,219 mm	40" 1,016 mm	6.375" 162 mm	21 lbs 9.53 kg	Black	2,500 lbs 1,136 kg	6,500 lbs 2,955 kg	100" 2,540 mm	36	39	1,200/ 30 Skids	720/ 20 Skids	780/ 20 Skids
DC4V HP 40x48	Twin Sheet Industrial Pallet High Profile	48" 1,219 mm	40" 1,016 mm	6.75" 171.5 mm	21 lbs 9.53 kg	Black	2,500 lbs 1,136 kg	6,500 lbs 2,955 kg	100" 2,540 mm	36	39	1,200/ 30 Skids	720/ 20 Skids	780/ 20 Skids

Industrial Pallet DC4, DC4V/DC4V HP

SPECIFICATIONS

DC4 40 X 48

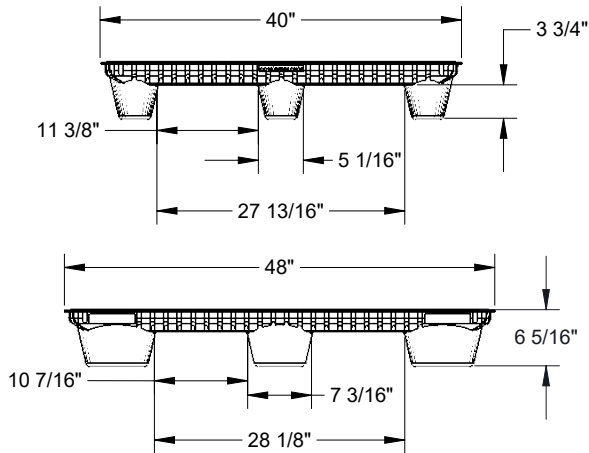

DC4 42 X 48

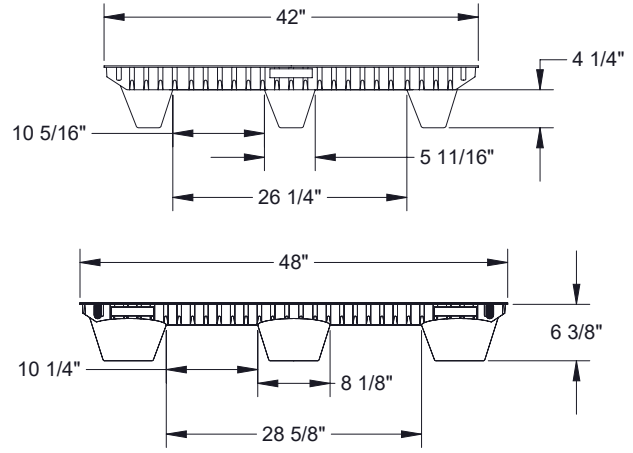

DC4V 40 X 48

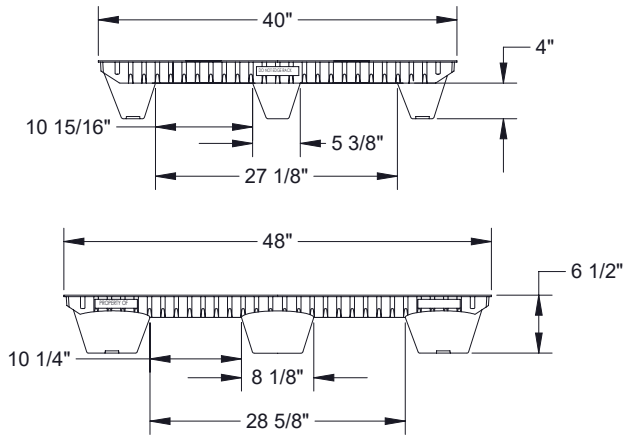

DC4V 40 X 48 HP

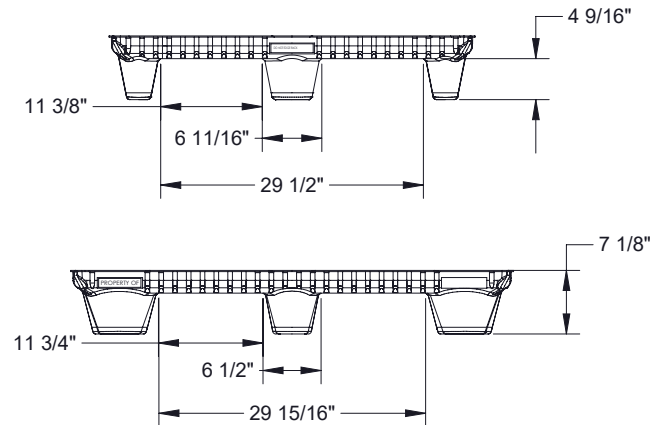

PALLET ADVANTAGES

- Environmentally Friendly
- ISPM 15 Exempt
- Long Service Life



TriEnda publishes standard guidelines for its products, based on its testing standards, and, as such, these guidelines do not constitute any warranty related to each customer's individual application. The material handling industry has not standardized on test methodology and rating criteria for each individual product. All TriEnda products are sold with the understanding that the customer will validate for themselves the suitability of the product for their specific application. As each product application is unique, the customer assumes all risks associated with the determination and actual use of the pallet.



CONTACT US

N7660 Industrial Road Portage, WI 53901
www.triend.com | sales@triend.com
 1-800-356-8150

**PALLET
BUYBACK
PROGRAM**

