

# PC10000 Series

## Passenger Car Wheel Packs

13" - 22"

Manufactured from HMW-HDPE

COVER



PALLET

### 01 / Details

TRAYS

#### FEATURES

- Conveyable
- Drain holes alleviate water accumulation
- Positive locking pallet base for safe and secure stacking
- Stackable by design for effective storage and return shipping
- Secure loads with shrink wrap or non-metallic bands in specially formed banding slots

#### OPTIONS

- Pallets, trays and caps allow shipping labels to be attached via wire tags
- Ergonomic hand and robot holes
- Custom stripe identification
- Custom colors
- Formed-in logos



Drain Holes



Custom Striping

### 02 / Specifications

PRODUCT #	DESCRIPTION	DIMENSIONS		COLOR	WHEELS PER LAYER	PER STACK		53' FULL TRUCK LOAD	
		L	W						
PC10000	Single Sheet Pallet	53"	44"	Black	-	36 Pallets		792 Pallets	
PC13000	13" Wheel Tray & Cover	53.5"	44.75"	Black	9/Tray	100 Trays	100 Covers	2220 Trays	2220 Covers
PC14000	14" Wheel Tray & Cover	53.5"	44.75"	Black	8/Tray	100 Trays	100 Covers	2220 Trays	2220 Covers
PC15000	15" Wheel Tray & Cover	53.5"	44.75"	Black	8/Tray	100 Trays	100 Covers	2220 Trays	2220 Covers
PC16000	16" Wheel Tray & Cover	53.5"	44.75"	Black	6/Tray	100 Trays	100 Covers	2220 Trays	2220 Covers
PC17000	17" Wheel Tray & Cover	53.5"	44.75"	Black	5/Tray	100 Trays	100 Covers	2220 Trays	2220 Covers
PC18000	18" Wheel Tray & Cover	53.5"	44.75"	Black	5/Tray	100 Trays	100 Covers	2220 Trays	2220 Covers
PC19000	19" Wheel Tray & Cover	53.5"	44.75"	Black	4/Tray	100 Trays	100 Covers	2220 Trays	2220 Covers
PC20000	20" Wheel Tray & Cover	53.5"	44.75"	Black	4/Tray	100 Trays	100 Covers	2220 Trays	2220 Covers
PC22000	22" Wheel Tray & Cover	53.5"	48.75"	Black	4/Tray	100 Trays	100 Covers	2220 Trays	2220 Covers

Performance characteristics vary with applications. To optimize nominal specifications, loads must be evenly distributed to reach capacity. Load construction, support conditions, transportation, load retention, user facility and temperature are factors that affect pallet capacity.

# PC10000 - Passenger Car Wheel Packs 13" - 22"

## SPECIFICATIONS

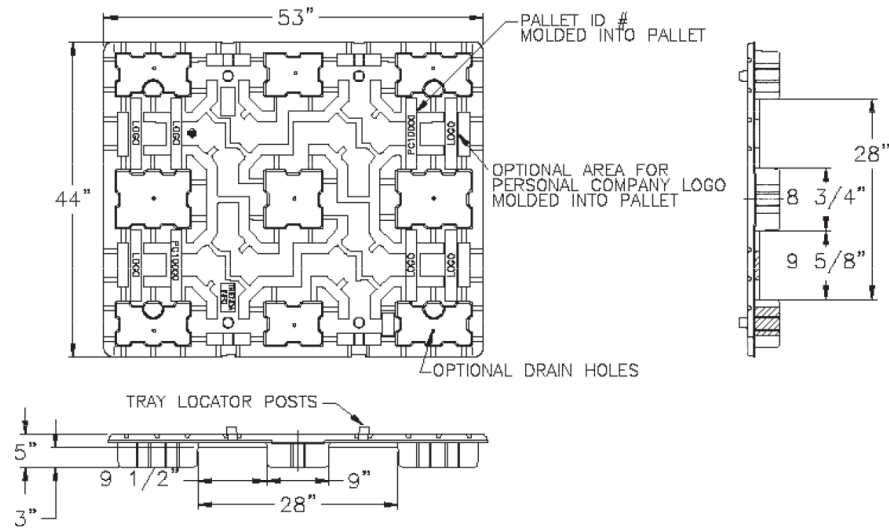

### PALLET

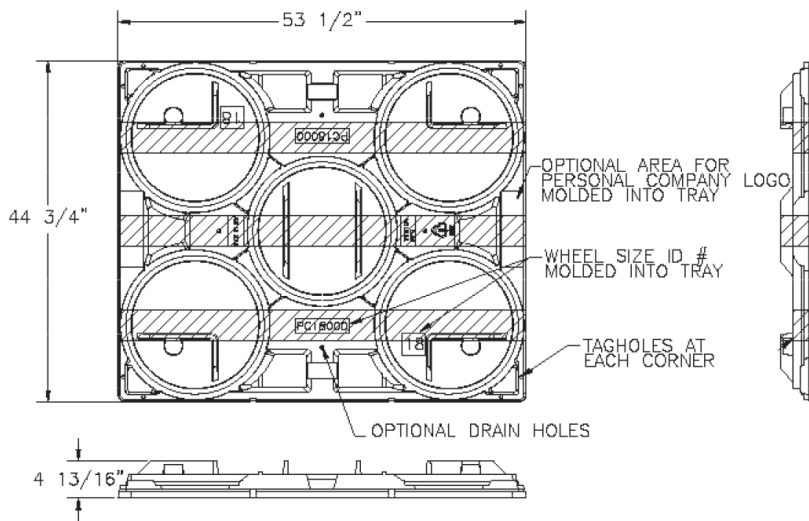

### TRAY

#### PALLET ADVANTAGES

- Environmentally Friendly
- ISPM 15 Exempt
- Long Service Life



Easy Clean



Sanitary



Impact Resistant



4-Way Forklift/jack Entry



Recycle

TriEnda publishes standard guidelines for its products, based on its testing standards, and, as such, these guidelines do not constitute any warranty related to each customer's individual application. The material handling industry has not standardized on test methodology and rating criteria for each individual product. All TriEnda products are sold with the understanding that the customer will validate for themselves the suitability of the product for their specific application. As each product application is unique, the customer assumes all risks associated with the determination and actual use of the pallet.

